

# FT-902DM

COMPETITION-GRADE HF TRANSCEIVER



# Yaesu

# FT-901DM

# &

# FT-902DM

# SURVIVAL GUIDE





### FT-902D / SD / DE / DM MODEL CHART

○ = Built-in feature      × = Available option

FEATURE	FT-902D	FT-902SD	FT-902DE	FT-902DM
FM UNIT	○	×	×	○
RF SPEECH PROCESSOR	○	○	○	○
AM FILTER	×	×	×	×
CW FILTER	×	×	×	×
KEYER UNIT	×	×	○	○
MEMORY UNIT	×	×	×	○
DC-DC CONVERTER	×	×	×	○
COOLING FAN	○	×	○	○
POWER OUTPUT	100 W	10 W	100 W	100 W
NEW BANDS	○	○	○	○

### Contents:

Introduction		page 3
Specifications		page 4
History of the FT-901D/DM and FT-902D/DM series	PAØPGA	page 5
Maintenance	PAØPGA	page 7
901/902 modules	PAØPGA	page 9
901/902 accessoires		page 14
Serial numbers		page 15
FT-901D Revival story	PAØPGA	page 16
Improving the FT-901/902	LA8AK	page 22
The 6146 family of tubes	K9STH	page 25
Ratings for the FT-901/902	eHam.net	page 27
Counter replacement module	JA2SVH	page 31
VFO stability story	WB5TKA	page 32
Interesting sites		page 15
FT-901 and FT-902 Trimmer boards		page 33



# FT-902DM

COMPETITION-GRADE HF TRANSCEIVER



## The FT-901DM and FT-902DM Survival Guide

### Introduction:

I will not go in detail on every nut and bolt of this transceiver, but only highlight my own experience and the experiences of fellow Hams.

This Guide is a collection of found facts from all over the Internet and other sources, collected in one volume for the benefit of the many FT-901/902 users who try to keep their equipment in optimal condition. It is not, however a modification guide for the "purists", who want to raise the "quality" of their sets, and by doing so ruin a beautiful piece of equipment. They have to do their own research.

The Guide is by no means complete, and if you have something to contribute, feel free to drop me a e-mail at: <http://wpenders@home.nl> or post it on the Fox-Tango forum.

I want to update this Guide if the need arises. The suggested modifications are always small and have a special purpose: to keep HF from the microphone, or a better protection of the power supply, to name a few. Included are also related articles, such as the excellent 6146B article by Glen Zook, and others, who are of interest for all the FT-901/902 users.

For your information: There is also a FRG-7700 Survival Manual and a FT-101ZD Survival Manual. You find them all on the Fox-Tango library for a free download. see <http://foxtango.org> I hope you will find something useful in this guide.

**73, Wim Penders PAØPGA**



## Specifications FT-901DM

Type:	Amateur HF transceiver	
Frequency Range:	10-160m, (early models had no WARC bands)	
Mode:	SSB/CW/FSK/AM/FM	
RF Power output:	SSB/CW	100W
	AM/FM	35W
Sensitivity:	SSB/CW:	0.25 uV (10db S/n)
	AM/FM:	0.5 uV (10db S/n)
Selectivity:	SSB	2.4 khz @ -6db, 4 khz @ -60db
	AM	6 khz @ -6db, (with optional filter)
	CW	600 or 300 hz, (with optional filters)
Image rejection:	- 60 db (160-15m) - 50 db (10m)	
Display	analog + digital dial	
Power:	Mains,	100-235 V ac 50/60hz
	13.8 Vdc	Only DM models, DC-DC converter option for all others
Current drain DC:	Receive:	5.5 Amps, (1.1 Amps with heater off)
	Transmit:	Max. 21 Amps.
Impedance:	50 – 75 ohms,	SO-239 connector
Dimensions	345 * 157 * 326 mm (W*H*D)	
Weight:	18 kilograms	
Manufactured:	1978 – 1982	
Accessoires:	FTV-901R	VHF/UHF/Oscar Transverter
	FV-901DM	Synthesised scanning external VFO
	FL-2100Z	Linear Amplifier 1200W SSB, 1000W CW
	SP-901P	External Speaker/Phone Patch
	FC-901	Antenna Coupler
	FC-902	Antenna Coupler with WARC Bands
	YO-901	Multiscope

### FT-902DM SPECIFICATIONS

#### GENERAL

**Frequency coverage:**

1.8–2.0 MHz, 3.5–4.0 MHz, 7.0–7.5 MHz, 10.0–10.5 MHz, 14.0–14.5 MHz, 18.0–18.5 MHz, 21.0–21.5 MHz, 24.5–25.0 MHz, 28.0–29.9 MHz

**Power requirements:**

AC 100/110/117/200/220/234 V, 50/60 Hz; DC 13.5 V, negative ground

**Power consumption:**

AC 117 V: 70 watts receive (45 watts HEATER OFF), 320 watts max transmit; DC 13.5 V: 5 A receive (1.1 A HEATER OFF), 21 A max transmit

**Size:**

342(W) x 154(H) x 324(D) mm

**Weight:**

Approx 18 kg

#### TRANSMITTER

**Emission:**

LSB, USB, AM, CW, FM, FSK.

**PA input power:**

SSB – 180 watts PEP

CW – 180 watts DC

AM, FM, FSK – 80 watts DC

**Carrier suppression:**

Better than 40 dB

**Unwanted sideband suppression:**

Better than 50 dB @ 1000 Hz

**Spurious radiation:**

Better than 40 dB below rated output

**Transmitter frequency response:**

300–2700 Hz (–6 dB)

**3rd order distortion products:**

Better than 31 dB below rated output

**Stability:**

Less than 300 Hz drift from a cold start; less than 100 Hz drift over a 30 minute period after warm-up

**RF negative feedback:**

6 dB at 14 MHz

**Modulation type:**

SSB—balanced modulator; AM—amplitude modulation of a low power stage; FM—variable reactance frequency modulation, maximum deviation ±5 kHz

**Antenna output impedance:**

50–75 ohms unbalanced

**Microphone impedance:**

500–600 ohms (low impedance)

#### RECEIVER

**Sensitivity:**

0.25 μV for S/N 10 dB

**Image rejection:**

1.8–21 MHz—better than 60 dB;

28 MHz—better than 50 dB

**IF rejection:**

Better than 70 dB

**Selectivity:**

WIDTH control at “0”

SSB 2.4 kHz (–6 dB), 4.0 kHz (–60 dB); CW/FSK (with optional CW filter installed) 0.6 kHz (–6 dB), 1.2 kHz (–60 dB); AM (with optional AM filter installed) 6 kHz (–6 dB), 12 kHz (–60 dB); FM 12 kHz (–6 dB), 24 kHz (–60 dB)

**Passband tuning:**

Continuous from 300 Hz to 2.4 kHz

**Audio output:**

Better than 3 watts @ 10% THD, audio output impedance 4–16 ohms

Specifications subject to change without notice or obligation.





## History of the FT-901/902 series transceivers.

The **FT-901D/DM** was introduced in early 1978, and was a immediate success on the amateur market. It is the real ascent of the highly successful FT-101 series transceivers, that Yaesu introduced in 1968, and produced in ever increasing numbers until 1979, when the last of this series (FT-101F) were sold.

By this time every amateur had learned that this and other Japanese "riceboxes" had a number of never-before possible features, and a good quality. The new transceivers had also very good signal on the air. All this and a very competitive price. Who could resist??

At the same time the legendary American manufacturers of amateur equipment lost the contact with the amateur market, produced sets that nobody wanted, or sets with almost the same specs, for a ever increased price. Their sets were very basic, for every option you had to pay a small fortune, that just a couple of Hams could effort. Well the times of the Gold Dust Twins were really over, and several of the old names folded or were taken over by industries that had only a eye for the ever expanding commercial communications boom, for services, police, fire, ambulance, where profits were bigger then in a relative small amateur market. So it is no wonder that transceivers as the Yaesu FT-101 series were a great success.

In the **FT-901D/DM** series the Yaesu engineers, had used all the feedback they got from Hams all over the world, forming the Fox-Tango group, whose members suggested improvements and even complete circuits, such as Harry Leeming G3LLL's RF speech processor, to name one.

Their modifications and suggestions were even translated in japanese and seriously used by the Yaesu lab workers to implement in the newer series transceivers.

The result was an ever increasing quality, and much more features than ever before but still for a very reasonable price.

In the FT-901 the receiver section is very impressive, it is very sensitive, with a dual-filter variable IF bandwidth control, for a continuous variation of the IF passband from 2.4 khz down to 300 hz, to receive every signal optimally, without paying a small fortune on extra filters.

There is also a rejection tuning control for nulling out a interfering signal in the passband ( I love it). For CW there is a variable audio passband filter for a significant reduction of background noise and razor-sharp selectivity, not unlike a 800 hz commercial CW audio filter from a surplus source that I used together with my home-brew transceiver in the seventies.

The noise floor of the receiver was measured in the ARRL lab and was an impressive -135db, later this was confirmed in a RSGB test, and the dynamic range in CW was 85db.

That were numbers, never reached before in a production run amateur receiver.

There was also a very effective noise-blanker, with an automatic level system, for eliminating pulse-type noise, such as the at the time infamous Woodpecker over-the-horizon radar of our Russian friends that operated in the middle of the 20 meter band.

At the transmitting end, the numbers were just as impressive.

It included RF negative feedback for a pure transmission, a Power Amplifier with real transmitting tubes (2x 6146B), a RF speech processing for a bigger "punch" and a solid 100 Watt output on all bands.

You could work in all modes, SSB, CW, FSK, AM and FM, at the flip of a switch.

New was also the 10 second tune button which activated the transmitter for a safe 10 seconds for tuning purposes, so saving the PA and power supply from an excessive key-down time.

The FT-901DM had also a real Curtiss CW-keyer board, and a memory system to store one frequency, which eliminated for most operators the need for an external VFO for dual frequency operation.

The FT-901 has all-modes and has provisions for SSB, CW, AM, FSK and even FM, on all classic Ham-bands (160, 80, 40, 20, 15 and 10meters), even a not documented 11 meter position in the early sets, the later issue 901 and 902 had also the WARC bands.

Vox, break-in CW, a calibrator 100khz/25khz, Clarifier tuning for RX/TX were standard in all models.

The FT-901 has a built-in Power Supply, and requires only an antenna and a power source.

As a Base station it works on power from 100 to 234 Volts ac, 50/60hz.

A DC converter unit can be used for operation on 13.8 Volts Dc.

**FT-901 models:** Range: 160 – 80 – 40 – 20 – 15 and 10 meter band, allmode.

FT-901D, Curtiss keyer, Memory module and DC module as option.  
FT-901SD as above, 10 Watt output, for the Japanese market. No DC module.  
FT-901DE Economic version, w/o FM module, Memory module and DC module.  
FT-901DM This model included all units including a blower and the DC module

The late types FT-901D/DM have already the WARC bands, the new type counter and are more or less the same as the FT-902 model.

**FT-902 models:** Range: 160 – 80 – 40 – 30 - 20 – 17 – 15 –12 - and 10 meter band, allmode.

FT-902D, Curtiss keyer, Memory module and DC module as option.  
FT-902SD as above, 10 Watt output, for the Japanese market. No DC module.  
FT-902DE Economic version, w/o FM module, Memory module and DC module.  
FT-902DM This model included all units including a blower and the DC module

All FT-902 models have the WARC bands, the newer LSI counter and a improved RF board.

Filter options on all models:   XF-8.9GA   AM crystal filter 6 khz  
  XF-8.9HC   CW crystal filter 600 hz  
  XF-8.9HN   CW crystal filter 300 hz

Resuming: It is no wonder, that this transceiver was an immediate success, not only the specifications were exceptionally good, but it was affordable for the serious Ham.

Yeasu packaged the new transceiver in a very nice design, that is still impressive to see.

I for one, find the looks of the 101, 901 and 101ZD series beautiful, it looks the way a real transceiver should, knobs and switches are all in a very convenient position, with room for all my fingers, the set is sturdy built like a battleship: it seems undestructable, and with a weight of 18 kilogram, it is a real new-age boat-anchor, and a future collectors item. I am sure about that!

The FT-901 set a standard, that now, even after almost 25 years is very difficult to reach by other equipment, and you have to pay top dollars for something better, and that is certainly no amateur-radio product. It was in a way a Ham's dream come true.

At the time it was the best you could buy for your dollar, and if the price-tag was higher than you could effort, you could settle for the FT-101ZD, for top performance in SSB and CW at 70% of the price of an FT-901.

But now, after all this time, I can compare between the FT-901D and the two FT-101ZD's that I own, and I must admit that the FT-901D is really a standard of its own, and worth every dollar you have paid for it.

If you see one for sale in a good condition, and a reasonable price, grab it, you will not regret it !

Unfortunately, they are seldom for sale. I think because everyone who owns one, like to keep it and when they are sold, prices on e-bay are pushed over the limit.





## FT-901/902 Maintenance:

The **FT-901/902** is build in a modular way, that makes access to the the parts easy if you have the right extender boards, (a very difficult find). The screening between the modules is very good, resulting in a very good stability and the important alignment points are all in easy reach from the top of the boards, although I had liked some test connection pins there too, for connection of a scope or other measuring equipment to critical points.

The VFO is very stable, is basically the same as used in the FT-101ZD, and uses a precision gear to display the frequency on a very accurate dual analog scala which can be set to within 500hz.

There is also a digital counter display, who displays the true carrier frequency, so no out-of-band errors anymore.

The counter displays the frequency accurate to 100 hz.

All circuits are solidstate, except the driver and the Power Amplifier, they have tubes.

The complete **FT-901/902DM** has some 2800 components. They will, if the transceiver is used properly, last practically forever, the only trouble points are the elco's in the powersupply and elsewhere, but that goes for every piece of gear after 25 years.

In general, the most troubles are coming from overloading the Power Amplifier and driver, or from inexpertly working on circuits (Man-made faults).

I can give only one advice in this respect: Don't work on this or other complicated equipment, if you are not familiar with it, the results are always worse then when you started, and, while you may afterward donate the set to the graveyard of the Fox-Tango community, that is not the way to do things.

If you want to use this transceiver in any way, it is a necessity to read at least the **Owners Manual**, and study the detailed explanation of the used circuits.

For serious work, you need the very good (200+ pages) **Maintenance Service Manual** for the FT-901 and FT-902 that you can [download from the Fox-Tango library](#). It has not only a detailed circuit description, but also a section with all the modifications that where used trough the years, the foil patterns and voltage cards of all boards, a trouble shooting guide and a parts list. The last section deals with the FT-902, and the newer WARC boards.

That manual should be your bible, and is for Fox-Tango members free to download in PDF form from the Fox-Tango library site. There you will find manuals for the majority of the Yaesu transceivers and accessoires.

In the Fox-Tango groups you will find a lot of helpful people, who are keen to help you, if you run into trouble, or have some questions. There is a special FT-901DM group too.

This site resembles me of the old days, when everybody was building his own equipment, and had on-the-air or practical help from the hams in his neighborhood.

That was Ham-Radio at its very best!

The neighborhood is now worldwide thanks to Internet, and help is just a few keystrokes away.

Do not begin to disassemble your precious FT-901, before you have studied the Maintenance Manual and you understand the function of all circuits.

A word to the wise: BE CAREFUL, on several places in this transceiver there are high voltages ranging from 100 V to 850 Volts. That are very unhealthy voltages, which can be fatal, if you are unfortunate, and a real eye-opener if you are lucky !

### Inspecting

If you have a good working FT-901/902, there is no need to disassemble the set, but as in all sets of this age there are now and then some small alignments to make, or they can develop a fault, that has to be corrected, and then you have to take things apart.

If you have obtained a FT-901 from a sale or hamfest, you best start giving it a good look over, in that way you will gain a good working knowledge of the general setup and the used modules.

The Maintenance Manual is a very good help to locate parts and modules.

The other benefit is that you so will discover all changes and modifications done, and potential trouble spots: discolored or burned resistors, gassy tubes and more undesirable discoveries.

By all means, take your time. A job like this is not done in an evening or two. If you rush things, you will make mistakes that cost a lot more time to correct in the end, and a lot of frustration too.

Give special attention to the power-supply boards, because most problems are power related, and they can cause a lot of troubles on other boards.

Measure the bleeder resistors over the elco's, and, if they are off the mark, change them. Otherwise the voltage over the elco's is uneven distributed, and they are pushed to the limit of their voltage rating. Sooner or later they give up, often



with a big Bang, and with some damage to the surrounding boards, not to speak of the mess of the exploded innards of them. You will never believe how much stuff comes out.

If it happens, you have to clean everything, because the stuff is corrosive and will effect everything it touches.

Carefully inspect every item for damage or for signals such as burned or discoloured resistors, or hot-spots on boards. You have the set apart now, so you can save a lot of time later by inspecting every hook and corner.

It seems stupid to say, but a good repairman uses his eyes, nose and fingers more than his service instruments.

That way he discovers almost 80% of the faults he encounters. They have a nose for trouble !

By carefully inspecting, you gain a good working knowledge of how things look and work, that helps you to use the transceiver optimally, when you are ready to use it.

## Cleaning

For cleaning of all equipment I use a good kitchen cleaner, a collection of small paintbrushes, a old toothbrush and a old T-shirt to dry everything.

To remove fat, nicotine and other debris, I use the cleaner direct on very dirty pieces.

After taking off the debris, all is rinsed with a wet paintbrush again, and dried with an old towel.

Knobs and removable parts are cleaned seperately, I brush them completely off with a soap solution , let it soak for 1-2 minutes, rinse them under the tap, sweep them dry and let the unit dry in the sun.

After thorough drying, I brush them off with a dry paintbrush or toothbrush to remove all small particles that are left.

After a visual inspection of all soldering joints for pitting or cracks, the component can be assembled again in the mainframe, that you have cleaned first of course.

While you are at it, check all pots and switches and clean and lubricate if necessary. I use a tuner cleaner for this because it leaves no residu on the contacts. Clean all board connectors, they can be a trouble source too.

If I have to lubricate I use a good quality contact cleaner. Use it sparingly, otherwise everything is greasy again. If in doubt do no lubricating, sometimes lubricating makes things worser then before.

The innards of switches can be difficult to reach for a spray, because they are completely closed. Some like the small push-button switches are rather easy to dismantle, by pushing back the spring, and taking out the U formed wire router. Then you can carefully pull out the innards, and clean the contacts. Re-assembling is in the reverse order. It seems difficult, but is a easy job if you can reach the spring and router. Otherwise, try to get some contact cleaner in the switch, and work the switch vigorously for some time.

If necessary, and if all other methods fail, you can drill a very small hole in the switch from the end, and squirt some cleaner in it. Close the hole afterwards with a piece of tape.

The potmeters are easy: Use the contact cleaner and turn the pots several times, that will do.

After a good cleaning job, I polish the covers with a good automobile wax, to restore them in as-new condition.

Be careful to apply this to the front however, it works good there too, but the wax residu is very difficult to remove from the deeper lying parts of the frontplate, and give a whitish residu.

Remove with a dry toothbrush, if necessary.

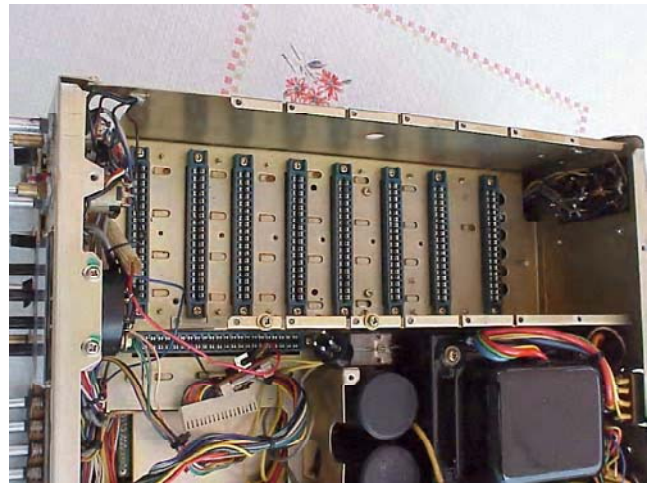
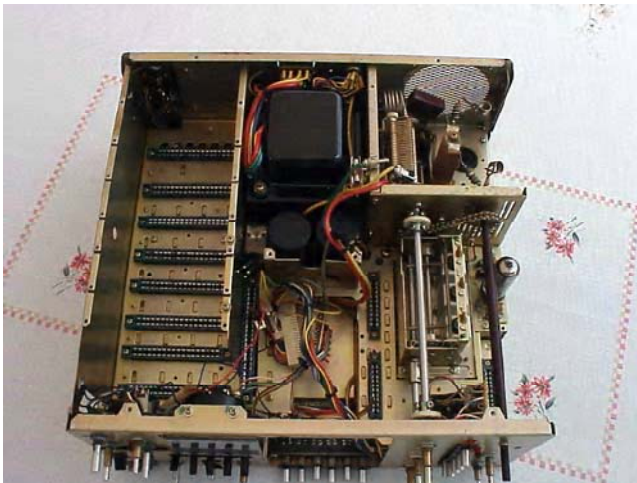

My FT-901D chassis with all modules removed after a good cleaning job



## The FT901 module Units

Here is a list of the boards used in the early and late FT-901 and FT-902  
Yaesu uses a board code in their schematics, to make it easy to find a component.  
Examples: TR-901 is transistor 01 on board 9, (FM unit).  
R-305 is Resistor 05 on board 3, (Filter board).

### The FT-901/902 boards:

Board Code	Unit	FT-901 early	FT-901 late, FT-902
1	RF unit	PB-1702	PB-2154A
2	Noise Blanker	PB-1703	PB-1994
3	Filter unit	PB-1716	PB-1995
4	IF unit	PB-1704C	PB-1704C
5	AF unit	PB-1705A	PB-1705A
6	Vox/Marker unit	PB-1846A	PB-1846B
7	Carrier unit	PB-1706A	PB-1706A
8	VFO unit	PB-1440	PB-1440B-3330
9	FM unit	PB-1707B	PB-1707B
10	Rectifier A unit	PB-1708	PB-1708
11	PLL unit	PB-1709A	PB-1709A
12	VCO unit	PB-1710	PB-2166A
13	Xtal unit	PB-1711	PB-2165
14	Rectifier B unit	PB-1712	PB-1712
15	Capacitor unit	PB-1713	PB-1713
16	Driver unit	PB-1714A	PB-1714A
17	Final unit	PB-1715B	PB-1715B
18	Rectifier C unit	PB-1717A	PB-1717A
19	Select switch	PB-1718C	PB-1718C
20	Lever switch	PB-1719B	PB-1719B
21	Tune switch	PB-1720B	PB-1720B
22	Led A	PB-1721B	PB-1721B
23	Reject switch	PB-1722B	PB-1722B
24	Trimmer A	PB-1723	PB-2190
25	Trimmer B	PB-1724	PB-2191
26	Trimmer C	PB-1092	PB-1092-3330
27	Keyer unit	PB-1728	PB-1728A
28	Memory unit	PB-1787	PB-1787E
29	Counter unit	PB-1729	PB-2086A
30	Display unit	PB-1730	PB-2098A
31	Diode switch unit	PB-1726	PB-1726A

DC-DC converter

### The differences between the used boards:

#### RF Unit , PB-1702/PB-2154A

There is a difference between the first and later series.

The first series boards (shown) uses two Fet's in the mixer.

In the later boards the circuit was changed to a double balanced diode ring mixer, using schottky diodes, apparently to improve the IMD.

As far as I can see, both boards are compatible, only the position of the sockets for J02 and J03 (TX and VCO) are reversed.

I have read a posting on Fox-Tango that someone has actually used this later board in a early type FT-901DM with good results.





### Noise Blanker, PB-1703C/PB-1994

The boards are functionally the same, but several transistors were changed: 2SK19GR was changed to 2SK168D, all 2SC-372 changed to 2SC1815Y, Germanium diodes 1N270 changed to 1N60, Xtal changed from 8532.5 khz to 8533.3 khz, in the later boards. My board is PB-1994 stickered, but the board itself is marked PB-1703C. The Xtal is 8532.5 khz.

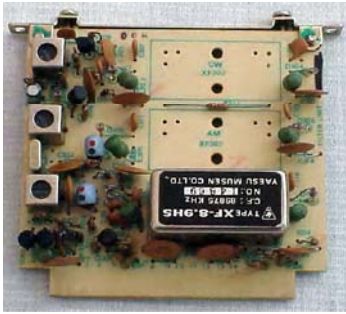

### Filter Unit PB-1995

This board is the same in every FT-901, except in the first series, the 2SC373 transistors were changed to 2SC1815, the germanium diodes were first 1S1007, later 1N270 and still later 1N60

Filters: 8.9M-20, XF-8.9HS,  
Optional filters: XF-8.9GA (AM) or XF-8.9HC (CW, 600hz),  
Later there was also a 300 hz wide CW filter (the XF-8.9HN) available, but you had to re-align the carrier frequency to use it. Most users changed it back to the more comfortable 600hz filter and use the audio filter.

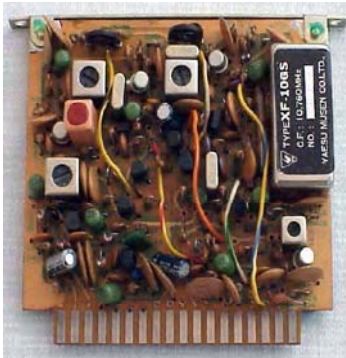

### IF unit PB-1704/PB1704C

For all practical purposes, all IF units are the same, the only difference between the early and the later types is a change in transistors: 2SC373 changed to 2SC1815, 2SC735 changed to 2SC1959Y

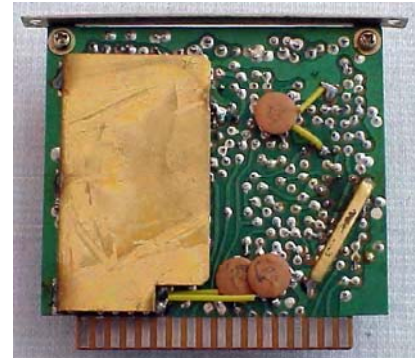

### AF unit PB-1705/PB-1705A

In this board only a change in transistors: 2SC1000GR changed to 2SC732TM



### Vox/Marker unit PB-1846/PB-1846B

Only changes in transistors: 2SC373 changed to 2SC1815GR, 2SC735Y changed to 2SC1959Y, 2SC1815 changed to 2SC380TM-Y. Diode 1N60 changed to 1N270, some condensers were changed from ceramic to dipped mica.

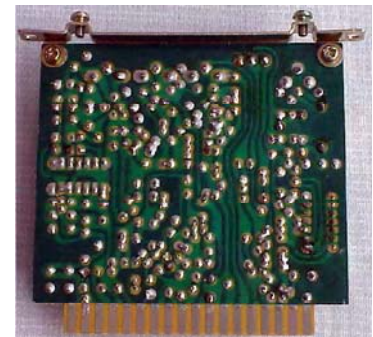





### Carrier Unit PB-1706/PB-1706A

Only transistor changes: 2SC-373 changed to 2SC1815Y, 2SC1000GR changed to 2SC372TM-GR



### VFO unit PB-1440/PB-1440B

Transistors: 2SC372Y changed to 2SC380TM-Y, C807/808/811/813/818 and C822 are all changed to dipped mica instead of ceramic, for improved stability.



### FM unit PB-1707/PB1707B

Xtal X-902 changed from 8987.5khz to 8988.3 khz.  
Optional Xtal filter XF-8.9GF

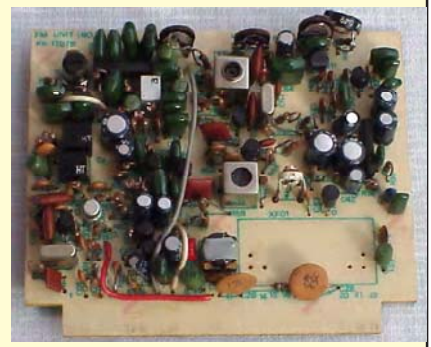

### Rectifier A unit PB-1708A

No changes, check that a diode modification in the screen supply of the PA is done in sets with a serial number prior to 08xxxx, otherwise by arcing of the PA tubes, the elco's on this board blow up, and almost always crack board PB-1717A, the Rectifier C unit, that is positioned next to it. It is a good idea to put a piece soft plastic or plain epoxy (no copperclad) between both boards to receive the impact. If this situation occurs, there is less damage.



### PLL unit PB-1709A

Here transistor Q1108 changed from 2SC373 to 2SC1815GR. No further changes.

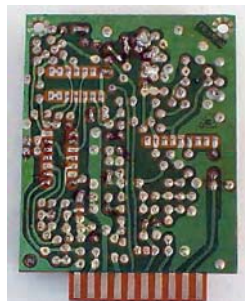

### VCO unit PB-1710/PB-2166A

The new board has provisions for all bands, including the WARC bands. The WWV 15Mhz position and the optional 11meter position were omitted. This board is not interchangeable with the older transceivers. Shown is the early FT-901 board PB-1710

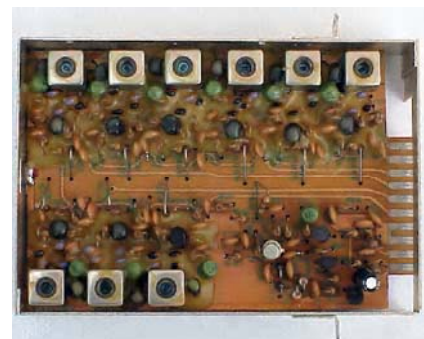



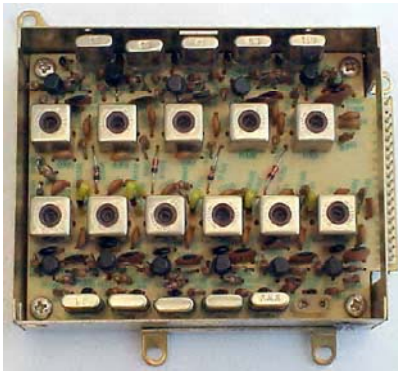

#### Xtal unit PB-1711/PB-2165

The new board has provisions for all bands, including the WARC bands. The WWV 15Mhz position and the optional 11meter position were omitted. This board is not interchangeable with the older transceivers

#### Rectifier B PB-1713 and PB-1712

(No picture) This board is the same in every transceiver and supplies the 850 Volt for the PA anode.

Check R1405 and 1406 (470k) for equality, they form a voltage divider over the elco's and must be the same, otherwise one elco has a higher voltage on it than the other, and, because they are working close to the limit (500V), you better check, before you experience a nasty Big Bang.

You can also measure the voltage over each elco, they should be nearly the same. (You can measure the voltage over R1405 and R1406).

#### Driver board PB-1704A

This board is the same in every transceiver (FT901/902 and FT-101ZD)

#### Final Board PB-1715B

This board is the same in every transceiver (FT901/902 and FT-101ZD)

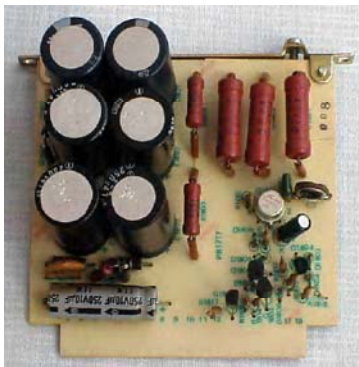

#### Rectifier C unit PB-1717A

There are no changes in this board. If you experience some VFO drift, check the 6 Volt supply of this board, or modify the regulator board with an 78M06 regulator IC for a better stability.

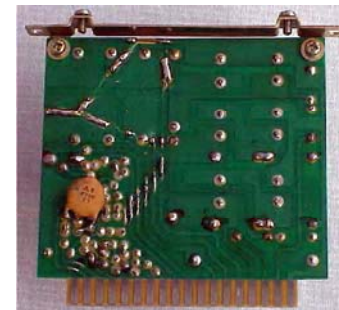

#### Select Switch board PB-1718C

No changes

#### Lever switch board PB-1719B

No changes

#### Tune switch board PB-1720B

No changes

#### Led A board PB-1721B

No changes

#### Reject switch board PB-1722B

No changes

#### Trimmer A board PB-1723C/PB-2190

Changed for the inclusion of the WARC bands, some condensers and trimmers added.

#### Trimmer B board PB-1724C/PB-2191

Changed for the inclusion of the WARC bands, some condensers and trimmers added.

#### Trimmer C board PB-1092-3330

2 capacitors added for inclusion of the WARC bands.

#### Keyer board PB-1728A

In versions prior to serial 08xxxx, the Curtiss 8043 IC was used, in the later versions a 8044 IC.

#### Memory unit PB-1787B/PB-1787E

Changes in transistors: 2SC372Y changed to 2SC1815Y, 3SK40 dual gate mosfet changed to 3SK51-03

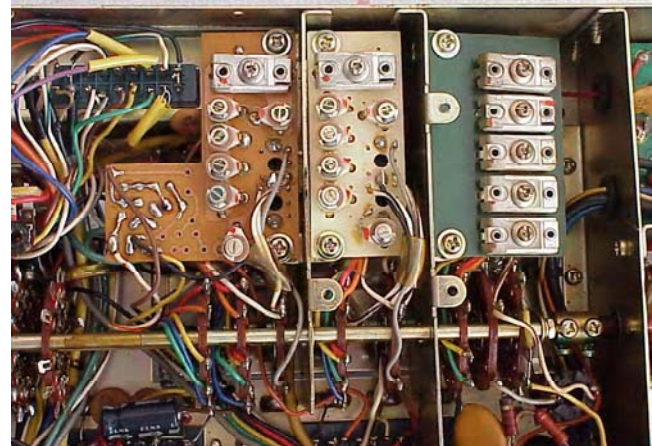





**Counter and display unit PB-1729A/PB-1730 (early model) , PB-2086A/PB-2098A (late model).**

The Counter module has changed in the late versions of the FT-901 and all FT-902 transceivers.

The early counter used C-mos and TTL IC's to display the frequency on 6 HP 5082-7740 red LED displays.

The counter used a mixing scheme for a correct display of the signal carrier frequency. It had to be re-calibrated in all modes to display the correct frequency.

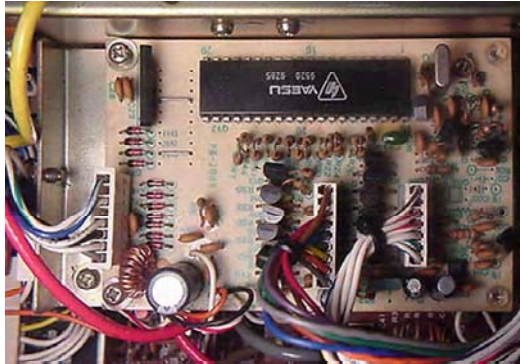

The later counter used a custom made LSI chip, made by OKI, the MSM-9520RS, which greatly simplified the circuit, because the chip displayed automatically the right carrier frequency, without recalibrating. The multiplexed output of the counter is displayed by 6 HP 5082-7623 yellow LED displays, the same as used in the later versions of the FT-101ZD, the FT-107M and others.

The main problem of this circuit is, that by a failure of the MSM-9520RS chip, and that seems to happen rather often, there is no replacement chip available, and you can use the transceiver only with the (rather accurate) analog dial.

You will not be happy with that.

Fortunately there is a solution: A Japanese amateur programmed a PIC processor to do all the functions of the MSM-9520RS. He sells a kit with a small board that fits in the existing counterboard, replacing the defect IC. In this Guide you find a page with a detailed description and the address where the kit can be ordered.

[http://homepage3.nifty.com/RadioGaGa/COUNTER\\_e/](http://homepage3.nifty.com/RadioGaGa/COUNTER_e/)  
It is easy to see at a glance which counter module is used in the FT-901:

The TTL counter had a red display, the LSI counter had a yellow display. If the set is not on you can see it this way: In the TTL version there is a small knob left of the display, marked Calibrate, in the LSI version it is marked Dimmer.

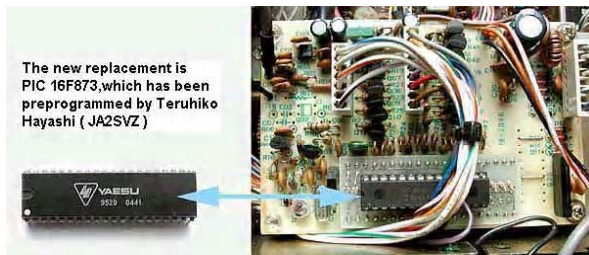

The new replacement is PIC 16F873, which has been preprogrammed by Teruhiko Hayashi (JA2SVZ)

**Diode switch board PB-1726A**

Some transistors changed: 2SK19GR changed to 2SK19TM-GR, diode 1S1007 changed to 1N270.

**Main chassis:**

In the main chassis are several diodes changed from 1S1007 to 1SS97.

**Yaesu Serial Numbers**

The Yaesu serial number on the back of the set consists of a number, a letter and 6 numbers. You can see at a glance the age.

The first number is the year of production:  
9=1979, 0=1980, 1=1981 a.s.o.

The letter is the production month:  
C= jan, D= feb, E= march, F= april a.s.o.  
(A and B are pre-production runs and not used)

The next 2 numbers are the production run: from 01 to ??

The last 4 numbers are the serial numbers: from 0001 to 9999





# FT-901DM accessoires



## FV-901DM external VFO

This is an external VFO that provides a synthesized control system for your FT-901DM. It has a 3-speed scanner, which will take you instantly everywhere in the band, and the auto-scan feature sweeps the band until it finds a signal. The synthesizer has a step rate of 100 Hz and is coupled to a 40-memory bank for storing the frequency. Fine tune is done with the TX/RX clarifier.



## FTV-901R transverter

The FTV-901R is a 3-band VHF/UHF transverter, all in one compact case. The basic FTV-901R comes equipped for 144 – 148 MHz. 6 meter and 70 centimeter modules may be added. There was even a 4 meter module available in the UK. The satellite 1-3 bands provide operation on OSCAR modes A/B/J on full duplex, when an external receiver is used. Repeater split is provided on 6 and 2 meters.



## YO-901 Multiscope

The YO-901 Multiscope provides superb monitoring capability, with an instant interface to the FT-901DM and can be used to monitor the output signal with trapezoidal and two-tone tests, general oscilloscope measurements are also possible. A panoramic adapter is an available option for a quick band activity examination. IF rx and tx monitoring is possible when the optional board is built-in.



## SP-901P speaker/hybrid phone patch

The SP-901P features a shaped-response loudspeaker and a hybrid phone patch, allowing efficient operation during patches. Styling and size match the FT-901DM and FT-101ZD series.



## FC-901/FC-902 Antenne coupler

The FC-901 antenna coupler presents a 50 ohm load to your FT-901DM transceiver, all across the band. 3 coax-fed and one random-wire antenna may be accommodated. SWR and Power metering allow quick determination of proper matching conditions.

The FC-902 is the same, but covers also the WARC bands.



## FL2100Z Linear Amplifier

The FL-2100 is specially designed for the FT-101ZD and FT-901DM transceiver. It uses two rugged 572B/T160 transmitting triodes in a class AB2 grounded grid configuration.

Power input is 1200 watts PEP on SSB and 1KW on CW, on all bands, including the WARC bands 10, 18 and 24 MHz.

The linear has 2 fans for cooling the final tubes, and special protection circuits for the output tubes and the tank circuit.

During standby the antenna is switched to the transceiver and the built-in SWR meter allows monitoring of the feedline during either amplifier or exciter-only operation.

The heavy-duty power supply requires no warm-up time and has excellent regulation.



## Hamfest shopping list:

It is always a good idea to keep your eyes open for special parts at hamfests. Often there are parts for sale at a moderate or even very low price.

There are several items to look out for, because they are not easy to obtain regularly.

**Relais:** RL1 = type AE3244, this is a National relais 4xW, 12Vdc, used for signal switching.  
RL2 = MX2P 12V, this is a Omron relay, 2xW, 12Vdc, used as antenna relay.

Although I never encountered a bad relay in one of my sets, it is a good idea to have a spare for each of them, for when the need arises.

The small signal relais that have been used in the clarifier and elsewhere in the transceiver are readily available, they are a standard Fijitsu relay, and are also made by Matsushita, Siemens and others.

**Dial lamp:** BF311/04071A, 14V/0.12A (fuse type lamp 5x20 used to protect the RF board)  
BQ-044/22839A, 8V/0.15A (dial lamp fuse type lamp 6x30)

**Meter lamp** axial bulbs with wires, 8V/0.055A

**Tubes:** 1x 12BY7A driver tube  
2x 6146B PA tubes, matched pairs if possible.

While they last long (very long if you have the habit of switching the heaters off during a longer listening periods), they are beginning to get scarce, so if you have the chance, collect a good supply.

Included elsewhere in this Guide is a very good article over the 6146 and equivalents, by Glenn Zook, who explains all about the 6146A/B/W you ought to know.

High Voltage elco's, for the HT power supply and the other supply boards:

100uF/500V, 22uF/400V and 47uF/250V are used, and they have to have same dimensions or smaller than the existing ones, modern types are almost always smaller.

Caution: Reformat them before using, Elco's that were long in stock, have to be reformatted, that is, they must be connected to a variable powersupply, and the voltage must be increased in steps toward the maximum voltage. If you put them directly to the maximum voltage, there is a chance that they explode like a nasty firecracker. Check for a date code on the elco's, the bigger ones have it ususally printed on them.

The IC's that are used in the FT-901/902 are not easely found, because several of them are special and are not produced anymore. But normally used, they give seldom problems, and they will last almost forever.

The same goes for the used transistors, some can be had in a good service shop, or postorder firm, others you have to substitute with modern types. Some, like the 3SK40M in the preamp, can be replaced by a 3SK51-03, but you have to change sometimes a resistor too for optimal pformance.

See page 3-20 of the service manual for Mosfet changes.

Switches can be a problem too, I encountered a defect heater switch, in my FT-901D, but I decided to dismantle the whole switch, and clean the contacts. It is a lot of work, because you have to take off the front panel, and the switchblock, just to get to it. It worked well and you can read how it was done in the FT-901 revival story.

### Sources for FT-901/902 information on Internet:

<a href="http://foxtango.org/foxtango001.htm">FoxTango International:</a>	<a href="http://foxtango.org/foxtango001.htm">http://foxtango.org/foxtango001.htm</a>
<a href="http://groups.yahoo.com/group/FoxTango/">Yahoo Fox-Tango group:</a>	<a href="http://groups.yahoo.com/group/FoxTango/">http://groups.yahoo.com/group/FoxTango/</a>
<a href="#">Other Yaesu equipment specific Fox Tango Groups:</a>	<a href="http://groups.yahoo.com/group/Yaesu_FT-7">http://groups.yahoo.com/group/Yaesu_FT-7</a> <a href="http://groups.yahoo.com/group/FT-620B">http://groups.yahoo.com/group/FT-620B</a> <a href="http://groups.yahoo.com/group/FTdx-9000">http://groups.yahoo.com/group/FTdx-9000</a> <a href="http://groups.yahoo.com/group/Yaesu_FT-227R_CPU-2500_users_group/">http://groups.yahoo.com/group/Yaesu_FT-227R_CPU-2500_users_group/</a> <a href="http://groups.yahoo.com/group/FT-901/">http://groups.yahoo.com/group/FT-901/</a> <a href="http://groups.yahoo.com/group/FT767GX/">http://groups.yahoo.com/group/FT767GX/</a>
<a href="http://www.rigpix.com/schematicsnstuff.htm">RigPix:</a>	<a href="http://www.rigpix.com/schematicsnstuff.htm">http://www.rigpix.com/schematicsnstuff.htm</a>
<a href="http://www.mods.dk/view.php?ListManuals=yaesu">Mods.dk:</a>	<a href="http://www.mods.dk/view.php?ListManuals=yaesu">http://www.mods.dk/view.php?ListManuals=yaesu</a>
<a href="http://www.eham.net/">eHam:</a>	<a href="http://www.eham.net/">http://www.eham.net/</a>
<a href="http://www.agder.net/la8ak/b21.htm">LA8AK FT-901 pages:</a>	<a href="http://www.agder.net/la8ak/b21.htm">http://www.agder.net/la8ak/b21.htm</a>
<a href="http://www.cbel.com/boatanchors_radio/?order=pop">Boatanchor sites:</a>	<a href="http://www.cbel.com/boatanchors_radio/?order=pop">http://www.cbel.com/boatanchors_radio/?order=pop</a>
<a href="http://bama.sbc.edu">Bama Boatanchor Manuals:</a>	<a href="http://bama.sbc.edu">http://bama.sbc.edu</a> and: <a href="http://bama.edebris.com">http://bama.edebris.com</a>





## FT-901D revival story

by Wim Penders PAØPGA

I have a A licence for almost 40 years, but not been active for the last 20 years, I had a busy job and not much time. Aged 62, I retired last year, and I have taken up the hobby again and am restoring old boatanchors such as the R-390a/urr, Racal RA17 and 117, BC342, and some measuring equipment. I love to tinker around and bring them back to life again.



I bought a FT-101ZD some 25 years ago, when they were introduced in 1979, and have used it all this time with much pleasure, and without any troubles. In the spring of this year I bought another one, more or less for spares. It had been used on 11 meters, and the PA was a mess with burned wires and other sins. However, I did not dismantle it for spares, because I could not resist the challenge to rebuild the PA and try to make the transceiver topfit. Well to make a long story short, (you can read it in the FT-101ZD Survival Manual), I am using this transceiver now in the living room beside my computer, and the set works now beautifully, although I could use a set of new PA tubes for it.

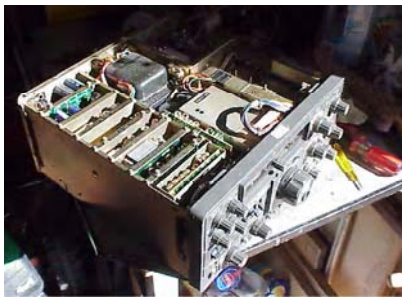

When I obtained the first 101ZD, I liked very much to buy the bigger brother the FT-901DM, because I was charmed by its many possibilities. The price difference over here was at the time more than \$ 700, and having a small family, with other preferences, I bought the FT-101ZD instead, but always have had an eye open for a chance to buy a used FT-901DM.



Last month I saw one on Internet, the seller had no picture of the set (a bad sign), and mentioned the fact that in his opinion the HV was defect, because he had no cathode current on the meter. I asked him if the receiver was working, and he said that the signals were faint and that the 10 meter xtals had been changed for 11 meters.

I expected not much, because they are always misused on 11 meters. The asking price was very good, (around \$ 150), so I decided to drive the 200km to see for myself before I made the deal.

Well, the transceiver looked mechanically sound, no dents and just some small scratches, was complete as far as I could see, and (luck) the owner had no knowledge of electronics, and had done the only sensible thing: not tried to "repair" the set.

The only thing was: The owner was a chain smoker, and lived alone in not to clean surroundings. The transceiver was very filthy and smelled like an ashtray, but no burned transformer smell. Testing was not possible.

Included in the deal was a Tono Theta 550 communication terminal and a small Cuna 2 meter receiver, so I took the lot home. For that money, you couldn't go wrong anyway.



After taking off the covers, I found a half pouch of tobacco distributed everywhere in the set, really unbelievable, so the first thing to do was grabbing the vacuum cleaner. The set was complete with all units except the memory and the keyer module, which was an option for the FT-901D anyway.

There was a added deviation pot on the FM board and 11 meter Xtals instead of the 10 meter Xtals.

So far as I could see, there were no signs of a cooked transformer, and the HV elco's seemed intact.

Both PA tubes had white rings around the getters, a sure sign for a gassy or a very overloaded tube .



After removing the PA tubes I decided to check the High Voltage first, to test the transformer, and check the receiver, if possible, before I started the task of cleaning this filthy piece. With a meter at the anode connection of the PA tubes, I crossed my fingers (very scientific), and switched on.





The meter says that I have a High Voltage of 850 Volts, there is no sizzling or other undesirable noises, but no reception either, just receiver noise with the audio full swing, no signals on 80 meters with a piece of wire. After connection of a antenna, still no signals. Test with the calibrator gives me S9+20 signals, so the receiver must be working, and the fault must be in the front end.

After some wiggling with switches and pots I discover that the attenuator switch is dirty, and I have signal now and then. I have now also sigs on 40 and 20.

For the moment I am satisfied that there are no serious problems.

I switch off and go to bed, it was a long day.

I will tomorrow first disassemble the set for a thorough cleaning, before I am glued to the knobs.



The next day I started with taking everything apart, as far as possible, to have a better access to the inner works, took out all the boards and units, took off all knobs and the frontplate, the PA covers, the trimmer covers and even the fan, who is relatively clean, so I think that this set is not so extensively used after all.

The previous owner told me that he had got the powersupply repaired, but had not used the set afterwards, because he had no IC reading on the meter anymore and was afraid to blow up the whole supply again.

In the Rect C module, are some elco's changed, a common issue with the FT-901 it seems, and a fairly sure sign that there was some arcing in the PA tubes. The debris of the exploded elco's is still in the last 2 compartments, the last board has taken a beating, and has been soldered together again. It is well done, so I leave the board that way until I can get a spare.

After all it seems that a very thorough cleaning job will restore this transceiver to normal.

I am used to that, every boatanchor that I own needed a good cleaning, before it was fit to be used in my shack.



### Cleaning:

For cleaning all equipment I use a good kitchen cleaner solution and some small paintbrushes and some old T-shirts that I scavenge from my wife's ironing room. The units were first scrubbed with the solution, and after soaking for one or two minutes, scrubbed again and then rinsed under the watertap, swept dry, an set in the sun to dry for some time.

After drying, I brush the unit off with a dry paintbrush, and check all soldering joints and contacts, for possible bad connections.

The frontplate is cleaned in the same manner, the yellowish paint around the knobs is real white again and the paint is as new, with some minor scratches.

The card connectors are cleaned with a piece of cardboard, bend double and used as a file. That removes all residues, and leaves a nice, shiny contact surface.

You really see the difference !

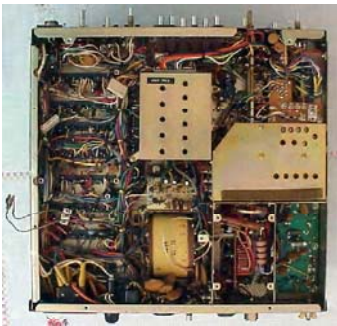

### Paint repairs:

For some minor paint repairs I use model paint: for the frontplate I used Revell (or Humbrol) nr 77matt, for the covers I used Revell (or Humbrol) nr 126 battleship grey. Eventually you can add a drop of black 302 to the nr 77. It is a close match, but you never have the exact color, so I will use paint very sparingly, there is always a difference in shade, and if the scratches are minor, I will let them be, it looks more natural.

You can find the used paint in every good model builder shop in 3cc tins.

I use nr 126 too for painting the screws that hold down the cover, because they have used some nickel plated screws instead of the original grey ones.

The nr 126 grey is almost exact the shade you need, there is almost no difference with the original color of the cover.





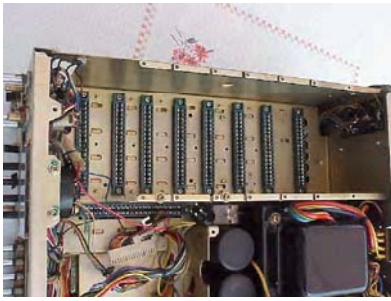

## Assembling:

The last of the transceiver cleaned, and the set re-assembled. I have now signals on 40 meters with my dipole connected, but somehow, the sound is not good. I checked the width control, it is off tune, and now the signals are getting better, although I find the span of the knob way to small. From one end to the other end of the filter just takes 60 degrees. I have to do something about that later.

I have signals on 40, but the S-meter deflection is much to low, compared with my trustful FT-101ZD although I have good solid signals. So the S-meter needs also adjustment.

Then another thing that catches my attention: I can't peak the preselector on 40m signals, I can turn from end to end and find just a small increase of signal around the 7 mark, but the peak is way smaller than on the 101ZD. Other things that need attention later: The APF led does not work, and there is no heater voltage at the driver tube ( at this point, I don't have the finals put in). I suspect the 12V heater supply or the heater switch, the tube measures good. Have to delve into it.

Other functions seem to work. (I am only testing in receive mode now), but it is clear that the set must be re-aligned.

That will take some time, because the procedure in the handbook is very strange, and postings on the net make it clear that other amateurs have problems too with the used alignment procedure.

I will first re-read how this was done in the FT-101ZD. That procedure can be used on the FT-901D as well, because the two have more or less the same receiver. First I leave the set on for some time, to see if there are no hot-spots, who need attention and to re-format the elco's. After a couple of hours, everything seems more or less ok, there are no smoke signs, only the 12 Volts for the heater is not present. Strange...

First playing with the receiver: The sensitivity seems compatible with my FT-101ZD's, but I have now more ways to manipulate the signal. I have a special liking for the reject tuning, it takes some S-meter points, but also a lot of QRN on a crowded 40 meter band.

Listening on 80 meters it is as easy to follow as a roundtable on 2 meters, in spite of the late-summer QRN. This receiver has a much lower noise floor than the FT-101ZD, it seems. If you can hear it by ear, there must be a big difference, I suppose.

I have heard hams complaining over lots of birdies and of strange signals on the bands, and some of them suspected that they where emitted from the memory module. Maybe they are right, because I can not hear any strange signals, only a military RTTY station that works exact at the IF frequency give some trouble, so I will have to re-align the IF trap in the preselector. (It is no mixing signal, because I hear it too on my trusty FRG-7700 on the exact 8989khz IF frequency).

Checked the 12 Volt heater circuit, and concluded it must be the heater switch, measured the resistance over pins 11 and 12 of the power connector, because that is the easiest way to measure: the switch contacts are connected to these, according the schematic.

By closing the switch the resistance should read around zero ohm, and around 35 ohms with the switch open, due the series resistor and the meter scale lamps, connected to them.

The test gives a high resistance by closed contact, so that's not good.

I have to rip the set apart again, this switches are very difficult to reach, even with the front removed. The best way to get to the switch is to remove the mounting bracket of the switches. That way it is possible to unsolder the wires and take the switch out. Mark the wires, it is important to attach them back in the same position. The switch has two sections, one for the heater, the other switches the fan.

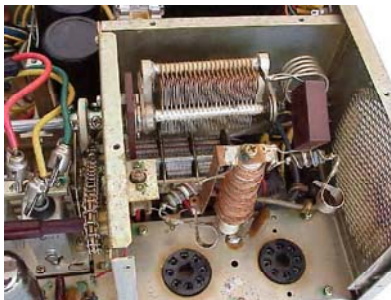



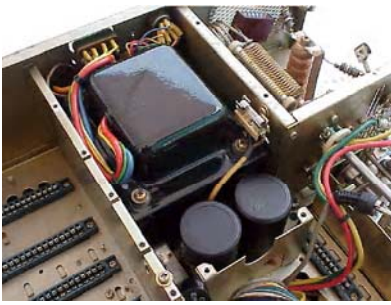

The two white wires are the fan connection, they are rather short, and difficult to reach. By taking the S-meter out of the way there is more room to work.

After taking out the switch, the contacts were measured again, and they have indeed some resistance, at both contacts. Now there are two possibilities: order a new one, if possible, or disassemble the switch, to try to clean the contacts. Because getting a spare will be very difficult, I try to fix the switch first.

Disassemble the switch by carefully knocking out the aluminium rivets that holds the assembly together. To do that, lay the switch on a piece of wood, with the rivet over a hole in the wood of 5 or 6mm, and tap the rivet out. If carefully done you can use the same rivets to assemble again, or you can use some small diameter bolt and nut for assembling. (Look for them in the model builder shop)

When the rivets are out, you can carefully remove the metal bracket and take the switch apart by pushing one side open. Be careful, the used material is bakelite, and it breaks easily. Don't apply much force, by gently probing, everything comes apart and you can take out both the fixed contacts and the movable contact. Careful by taking out the movable contact, it seems that they used some glue by assembling, and the case breaks easily, I discovered to my dismay. See the picture of the disassembled switch.



The contacts are heavy duty silver contacts, and with a cardboard strip, and some contact spray, everything is cleaned easily. Clean the contact by no means with a file, that will surely destroy the switch, use a special burnishing tool, or very fine (waterproof 800) sandpaper, if the contacts are in a very pitted state.

If something of the case breaks, you can repair it using quick bonding glue, but if you are more carefully than I was, there is no need for that.



Assemble the switches in reverse order, and tap in the rivets carefully. Use a centerpoint or similar tool to close the rivet, just by pushing it by hand. Do not use a hammer, the material is too soft, and breaks away.

If the heater contact was very pitted, and cleaning has not improved the contact, use the contacts of the fan switch to switch the heaters, and use the bad contacts for switching the fan.

If that fails there is a third possibility: As you can see in the pictures, the switch has a NC contact, that is not used. It is the contact in the middle of the switch. By using this and the common contact, and mounting the switch upside down in the bracket when you assemble, you have actually a new switch, that will last for another 25 years or so.

By turning the switch upside down, the On position is in the same direction as before.



Still another possibility: you can switch the fan by a small relay, that is activated by the 12 Volt heater voltage. You can build a small circuit for this near the accessory socket at the back of the transceiver, the switched 12 Volt is on this socket, and it is close to the fan socket. In this case you have to isolate the two fan wires at the switch, because they are running 100 Volts. I did this mod in my FT-101ZD, because the fan was not switched, and I found the fan noise annoying.

I did go deeper in this matter, because bad switches seem to be a common problem with the FT-101ZD and The FT-901DM.

A repair of them is easy, and save you the problem of finding spares.

The switch is a Matsushita switch WD-9223 (808) and has 10A/250Vac contacts. The contacts are rated at 10 Amps, but by working at a lower voltage there is maybe a lesser cleaning effect and more pitting than was expected by the Yaesu engineers.





After reassembling the FT-901, it was time to test the PA. The heaters were glowing, and after connecting a load, I tried to tune. All relays switched, there was some output, but no indication of current. That was the fault, the previous owner had described to me, but it was not the power supply, but the meter circuit that was not working.

Because the PA tubes were getting way to hot, I suspected that the bias was too low. The anode resting current should be 50 mA, but with the meter out, there was no way to check it now.

I measured the voltage at the grids of the 6146B, it should be around -65V in transmitting mode, but it was only -40 Volts, so the idle current was way to high. I aligned the bias to -65 Volt, and there was some output, but after further testing, the output fades away quickly.

I was using the original tubes, so I thought they were gone soft, and put in a set of new GE 6146W's, together with a new 12BY7A, but the results were almost the same.

I did not delve further in this for the moment, because I will look into this when I have changed the 11 meter xtals to the proper 10 meter ones and have obtained a proper dummy load.

The meter problem nagged me: The meter works fine in receive mode, but in transmit I get no deflection in either the IC, ALC or PO position.

After studying the (rather small copy) schematic, I saw that the meter is switched via relay RL1, and, because I had read that the relays could be a problem, I cleaned the contacts, and measured the contact resistance.

They were all good, but the problem remained. So it had to be the rocker switch on the front who switches the meter to the IC, Power output and the ALC.

Strange, because all other switches are working normally. Well, it was disassembling time again. After taking out some modules, the counter, VFO and the frontplate, I can take the switchboard out.

Fortunately I have the Service Manual, with the foil pattern and a detailed schematic of the board, and after some searching I find a connection point (15) that is not attached to anything, but should connect to the relay. After prying the cable harness apart, I find the loose wire. It is so short,

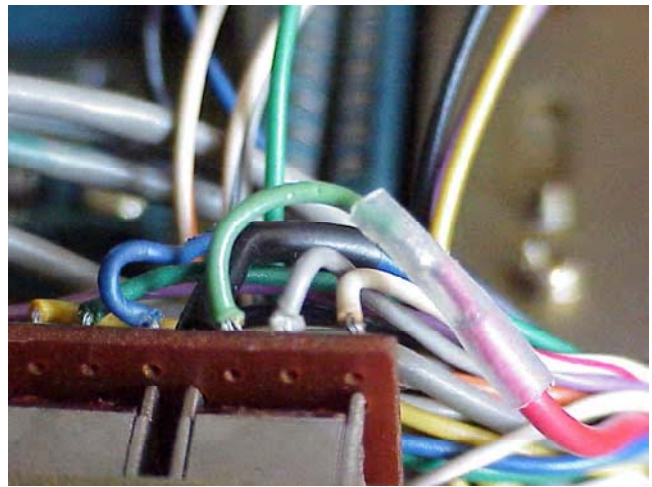
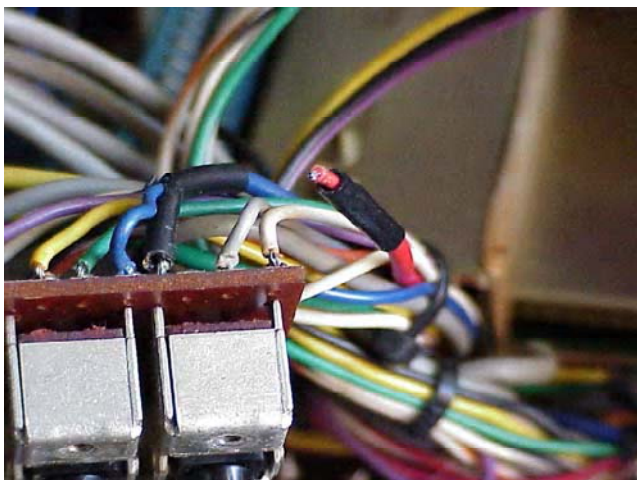

that it must have been broken off, the first time this switchboard was worked on.

There were signs that the switchboard was taken off earlier, by one of the previous owners, maybe to try to clean the switch contacts, because some of the small screws of the switches are missing.

I think they have been looking for the same fault.

I made the connection with a short piece of wire and some shrinking tube, to get more stretch in the wire, to prevent future problems.

While I was at it I sprayed the contacts of the switches with tuner spray, it can be applied via the upper mounting screw holes. I was able to test this by disassembling a similar switch, that was in my junkbox. The switches have sliding silverplated contacts, and should normally clean themselves. The switches are ALPS, and are also used in some audio equipment of the time.

After re-assembling, the meter works fine, and I am able to measure the IC current, ALC and the output power.

Time for a coffee-break.







The FT-901D after restoration, a big difference !



So far, so good, It took some time to bring this transceiver back to life again, but it was fun to do and I have now a fine piece added to my collection. I use it now daily to monitor the 80 and 40 meter bands. I like the receiver of it very much, when I compare with the FT-101ZD's I own, there is definitely less band noise, and the reject in combination with the width tuning, does a lot to make me able to copy signals, that otherwise are drowned in the QRM.

I have the luck that I live here in a rather noise-free location, and when I am listening in at several round-tables at evenings, I can hear all stations with a simple dipole, even the stations that others have problems with, so I am a very happy FT-901D owner now. I don't think it's leaving my shack again.

There are 2 band positions I can use for the addition of two WARC bands ( the WWV position, and a undocumented 27 Mhz position on the next position of the bandswitch), maybe I will modify them to take the 17 Mhz and 24 Mhz.

But I think I better try to get a good FT-902DM, that way I don't have to modify. I rather like to keep older equipment and boatanchors as original as possible.

#### Update: februar 2006

After receiving the 10m band xtals, it was necessary to re-align the VCO, but that was no problem, you have just to see that the VCO operates over the whole band section. I had the luck that there was not tampered with the display, but if they have, see the modification file for 27 Mc on FoxTango, and reverse the mods.

The PA tubes, although mis-used, still give a output of around 90-100 Watts, so I did not put in new tubes. Signal reports on the air are good, with no complaints about audio, so I am a happy FT-901DM user.

I have done some small modifications to the RF board, the Carrier unit and the Noise Blanker, and replaced the "deadly Cap" between the driver anode and the grid of the finals, with a 100pf 6Kv ceramic capacitor.

See the next pages.

Because all HV capacitors tested good, I did not change them. I think that the originals are better than the NOS pieces that you have to replace them with. The NOS have not seen voltages for a long time and may have a much shorter life. An advice: Change just what you have to.

73 to you all, Happy Hamming,

Wim Penders PAØPGA (wpenders@ remove home.nl)





# Modifications to the FT-901 RF board:

## RF Board PB 1702B

This board is used in the first series and has a RF amplifier, a dual Fet buffer/amplifier and a balanced Fet mixer.

Although this board works good and is sensitive as it is, it had for me a big disadvantage:

I have in my neighbourhood a very strong "telex?" type station that is operating exact on 8987 khz, right in the middle of the IF of the FT-101ZD and FT-901/902. This signal is so strong that it goes clean trough the mixer and so I had a constant, annoying signal, anywhere I tune when this station is active.

I have already tried to null the signal out with the IF traps that are in the receiver, that works to a degree, but now and then is this signal still strong enough to interfere.

In the last versions of the 101ZD and 901/902 Yeasu uses a different board (PB-2154) with a double balanced ringmixer, and I thought that could be the solution for me, because a DBM has a maximal isolation between in and output that can be as much as 60db. Maybe good enough for getting rid of this very cumbersome 8987khz signal.

After a study of the differences of the boards, I decided to give it a try to wire the 1702 board as the 2154, but using a DBM module.

I got a PB2154 board for a test, and this test showed that the interfering signal was so low, it did not bother me anymore. I could have leaved it at that, but decided to change a existing 1702B board with a DBM, as a test and for the benefit of other users with the same problem. Later I modified the boards of my FT-101ZD's too, they use a PB-1960 board, which is almost the same as the 1702 board. They had the same problems with IF signals getting trough the mixer.

### Modification:

As DBM I used a standard DBM HPF-505, that was on hand, but a SBL-1 or CM-1 should work also.

The only problem could be the conversion loss of the mixer, and thus a low signal level output to the filter. There has to be some amplification after the mixer, as on the 2154 board. I decided to use a J310 as a impedance converter and amplifier just as on the 2154 board.

First I removed all unnecessary components on the board: R136, R111, R112, R133, C126, C108, T101, Q104 and Q105.

Be careful, the print traces are easly lifted. Reconnect R113 from the midtap of T102 to the left pin (bottomside) of T102 and connect C109 direct from the same pin to ground at the foil side of the board.

Place J-310 at the right side, source to the middle connection of T102, gate to ground, drain to the previous gate point for connection to the mixer.

Place the mixer as shown in the pictures with a piece of dual sided tape, upside down and wire to the existing print traces:

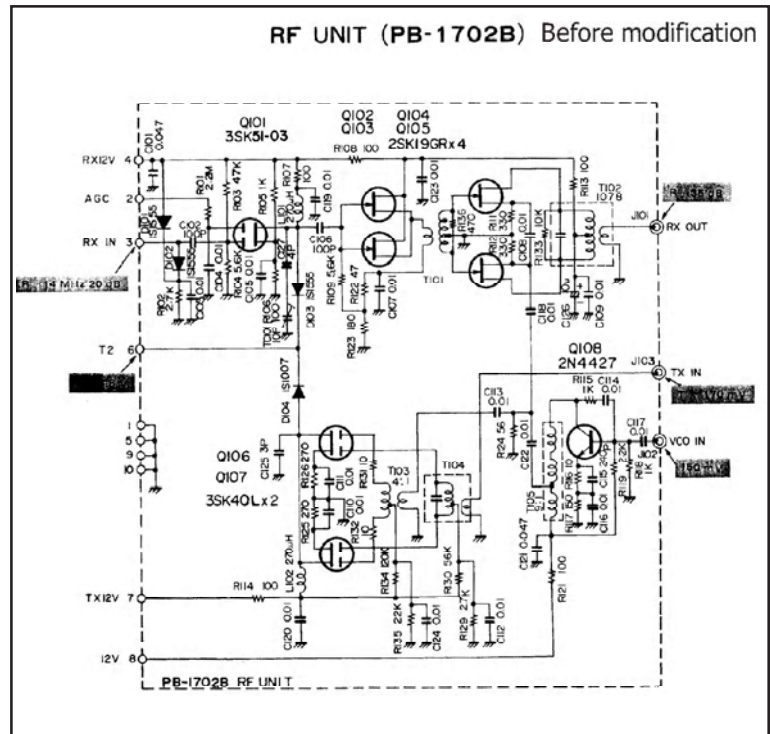



1 and 2 are connected to the 2 pins of the removed T101, pins 3 + 4 go to C118 (VCO)  
 Pins 5 + 6 are grounded ( do not ground the case, it is connected to pin 2, and carries some DC).  
 Pin 8 goes to the drain of the J-310, and a resistor of 22 ohm is connected to pin 7.

The connection of a DBM is rather standard, the input is at pin 1 and 2, here it replaces the input coil of T101, which is removed from the board, along with the mixer components.

The output is normally on pin 3+4, but I used them for injection of the VCO signal. That way I could use the low impedance output pins 8+7 for connection to the J310 in grounded gate. Pins 5+6 are grounded. The amplification can be adjusted by the Drain resistor of the output J-310, it should be adjusted to a drain current of maximal 20mA. I have used a 22 ohm resistor.

I first tested several other configurations with the 2SK19 as buffer, but they lacked gain, with the J-310 the signal output level is a somewhat higher than the 2154 board, adjustment is possible with the choice of the drain resistor (18-100 ohm, not lower).

**The results:**

What is immediately apparent is that the noise level is lower than of the unchanged print, lower than the atmospheric noise. A test signal of 0.05uV/50 ohm from my HP606 signal generator is easily heard, a signal of 0.5uV is good for a comfortable QSO, if the QRM is low. I have the luck to live in rather noise-free surroundings, and even on 40 sometimes the noise level is so low that I can hear all stations in a roundtable, with a simple dipole. I measured a sensitivity 0.1uV/50 ohm with both the 1702 and 2154 boards I swapped/tested.

The received signals with the changed board has better audio and there is less "splatter" from other stations, but I think the ringmixer modification on the carrier board is responsible for that (see the other mods.)

**My greatest pleasure of this modification is that I now got rid of this "telex" station on 8987khz, I have to peak the preselector now at the IF frequency to find a very faint signal.**

**Under normal operating conditions that signal is unaudible, even when it was S9 on my FT-101ZD.**

**So I have changed the PB-1960 RF boards of the FT-101ZD's too. (See below).**

Questions: Drop me a E-mail or put a posting to the FoxTango group.

Success, 73, Wim PA0PGA



**FT-101ZD RF board Mod.**

Modification of the PB1960 RF Board from the FT-101ZD goes more or less against the same lines.

Here a picture of the modified PB-1960 board.

On this I used a CM-1 DBM from my junkbox, but every other standard DBM will do. Works like a charm too.

All in all, a modification that takes only a hour or so to do. Recommended for European stations that have the same problems as I with this on the IF operating station. Transceivers that are using a 2154 board, have no problem, so there is no modification necessary.





### **901DM PB-1706A Carrier board**

Carrier adjustments: The most complaints for bad audio quality are coming from unadjusted carrier frequencies in your transceiver; after some 30 years they have to be adjusted for optimal audio in receive and transmit.

To calibrate the carrier frequencies: Connect a counter to the middle of pot VR-701

#### **Adjust in receive mode:**

USB: 8989.000 khz (trimmer C702)

LSB: 8986.000 khz (trimmer C701)

#### **Adjust in transmit mode ( PA heater switch OFF)**

CW: 8988.295 khz (trimmer C704)

FSK: 8988.125 khz (trimmer C703)

Repeat several times, until you get the exact values.

Output to the mixer:

USB/LSB: tx/rx about 2Vpp at the middle of VR-701 (measured with a scope)

CW/AM/FSK: tx ca. 3Vpp at the middle of VR-701

### **Modification of the diode ring mixer:**

Yaesu used here 4x 1S1007 silicon diodes, they are not bad but the performance can easily be improved, by using Schottky Barrier diodes such as the HP 5820-2800.

If you have the possibility, select them for equal forward current from a batch at the suppliers place, or order a special quad.

Selecting is an easy affair:

Use your multimeter in the diode range and connect to the diodes with a serial resistor of 4.7 K-ohm (value is not important). You now measure the forward current. Select 4 diodes that have the same value on the meter or as close as possible. In a normal batch it is rather easy to find 4 diodes with the same value.

Now, remove diodes D705 to D708 from the board and replace them with the schottky barrier diodes, in the same configuration, the ring end is the cathode.

After replacing, the bridge has to be aligned for maximal carrier suppression with VR-701 and TC-705.

Alignment is done in tx mode (**Heater switch OFF**) because it is most important to have a good carrier null for a clean output SSB signal.

Connect an oscilloscope to pin 4 of the print (SSB out), and null the oscillator signal with VR-701 and TC-705, repeat several times in USB and LSB mode for the lowest output. ( I had a value of less than 5mV in two cases.)

When you have selected equal diodes, both the pot and potmeter are near the middle of their range.

I measured the old 1S-1007 diodes, they were close but not as equal to each other as the schottkys.

Tests on 40 and 20 meters showed a audible lower noise level and much improved received signals, because the schottky diodes handle bigger signals more easily.

There is also less "splatter" from other stations (except the ones with their overdriven kilowatts and compressors), so it seems that not all splatter is generated on the band but also for a part in the receivers.

Listening on 40 and 20 shows that the average signal levels not much differ from before the mod, but the signals are much cleaner and the noise level is lower, ideal for DXing.

The noise level on the higher bands is lower than the atmospheric noise from the antenna, I can even hear a difference on 80m.

Signal comparisons have been done with my trusty FT-101ZD, on the same antenna and time.

The tx has now a much cleaner signal on the oscilloscope, with no flat topping, even when the mike level is fully up.

I use a standard Yaesu low-impedance hand mike and receive good modulation reports.

All in all it is an easy job, that results in a real improvement on both rx and tx side. I have later done this mod too on my two FT-101ZD's, with equally good results.

### **Noise Blanker improvement:**

Add a 100nF condenser parallel to C-328 on the Filter unit, (PB-1716C), it improves the off-time from the noise diode. Works good if you have trouble with ignition or other pulse noise. You may experiment somewhat with the value of the condenser.

Tests with a pulsed noise bridge showed an improved readability of weak signals of 3 S-points.

Another easy mod that reduces man-made noise using the Noise Blanker: Add a 100k resistor on the Noise Blanker/Processor board PB-1703C between C235 and D202 and ground. This resistor allows Q-207 to react quicker on normal bandnoise. It seems that Yaesu engineers have had the same thought, because on the print there are already holes drilled for this modification.

### **RF in the audio stage:**

Some sets have problems with a distorted audio due to the RF that reaches the microphone stage. The real fault here is a bad ground connection or a ground loop.

A 10nF condenser between every microphone pin and a common earth is in most cases enough to eliminate this, but proper grounding on one point, preferably at the antenna tuner, if used, is better. Try always to keep the RF out of your shack, It will give some very weird problems with your equipment.



## Improving the YAESU FT-901/902

### Circuit mods for the Ft-901/902

(90.12.20)

By LA8AK, Jan-Martin Noeding,.

#### PB-1705A AF Unit. Audio Quality.

This is in my opinion awful. Very bad bass-response. Looking at the FT-7 audio circuit, will show the solution. C511 to the AF-power- amplifier is decreased to 47nF (.047). Improvement is just unbelievable! Measuring the audio RF to audio response now

indicate that there are still more room for improvement, but it sounds good ..... even with the built-in loud-speaker, at least.

#### PB-1994 NB unit. Carrier Level Control.

This is a 5k potmeter, with effective 'range' of about 1000 ohm, ie. 80% of the rotation is outside practical control range. This potmeter is shunted with 1200 ohm, it is easiest to connect the resistor on PB-1994 (NB-unit) pin 5, and ground, or under the PCB-socket.

#### PB-1720B RIT. (Receiver Incremental Tuning = Clarifier)

One must decide self which RIT-range should be. In my experience the requirements depends on the operation.

HF SSB	+ 5kHz	HF CW	+ 1kHz	6M aurora	+ 5kHz.
6M CW	+ 5kHz	6M SSB	+ 5kHz	6M CW MS	+ 5kHz.
2M CW	+ 2kHz	2M CW MS	+ 5kHz	2M SSB	+ 5kHz.
2M Aurora	+ 5kHz	70cm CW	+ 5kHz	70cm SSB	+ 5kHz.
70cm Aurora	+10kHz	23cm CW	+ 5kHz	23cm SSB	+ 5kHz.



Jan-Martin LA8AK was a avid experimenter and a real Ham. He published regularly in various Ham Radio publications and had a very extensive webpage (still open), of WWII (mostly German) radio's. He died 11 april 2005 of an heart attack, during one of his favorite long walks near his QTH. His very interesting site is still available for his fellow hams on: <http://agder.net/la8ak/>

First I modified my rig for HF CW because it is very important to use correct tuning in HF CW contests. The modification shown in fig.2 makes +1.6/-1.5kHz (original is +5.5/-4.5kHz). VR06 is shunted with 1500 ohm resistor. Switch RIT on, set VR06 to center, tune RX to 7000.0kHz, switch off RIT and adjust VR01 to frequency reading 7000.0.

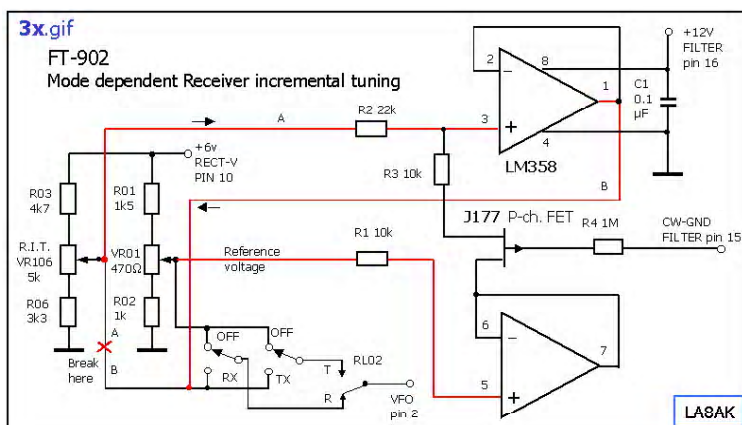
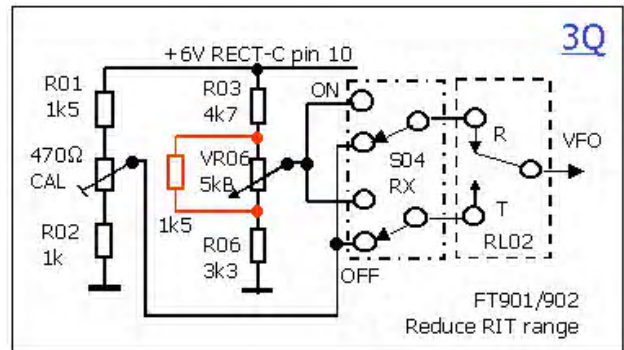

#### Mode-dependent RIT.

The modification as shown above was used for about one year, but it was a desire to have some further changes. The circuit shown in Fig.3 switches automatically between two RIT ranges, dependent on modes 1: AM/SSB/FM "wide" (+4.8kHz), 2: CW/FSK "narrow" (+ 1.4kHz) This is solved by using a dual-OP-amp, LM358=MC3358P1 (TL082 will not function). The circuit is connected on a printed circuit board. Some time was needed to find a suitable location, but at last it was mounted next to RIT-control, at the XTAL OSC. A little angle- bracket was soldered to one end of PCB and fixed using the two available screws which fixes the oscillator





assembly. VR01 is adjusted such that RX with and without RIT operate on the same freq. The transistor is a P-FET, which is not too commonly available, I used the only available, a J177 Switch-FET. For "narrow RIT" the FET reduces the gain, but center-frequency remains equal.

**PB-1994 NB-unit: RF-clipper (so-called RF Processor)**

It was not possible to notice any operation of this circuit, reports on the air did not indicate that this circuit did operate at all! I made some measurement using RF mV-meter connected to PB-1994 pin 17.

Whistling into the mike produced 70mV from NB-unit, while "blowing" into the mike produced 200mV rms, this indicate that RF clipper does not work on most sort of speech, while perhaps very good for single tone transmission..... The LIMITER (Q206 TA7060P) was suspected, a pair of 1N4148 diodes were mounted in antiparalell across the output from this IC, and the RF CLIPPER functioned !! Just as easy it was to improve this. The same suspect circuit has been seen in some other FT-line transceivers.

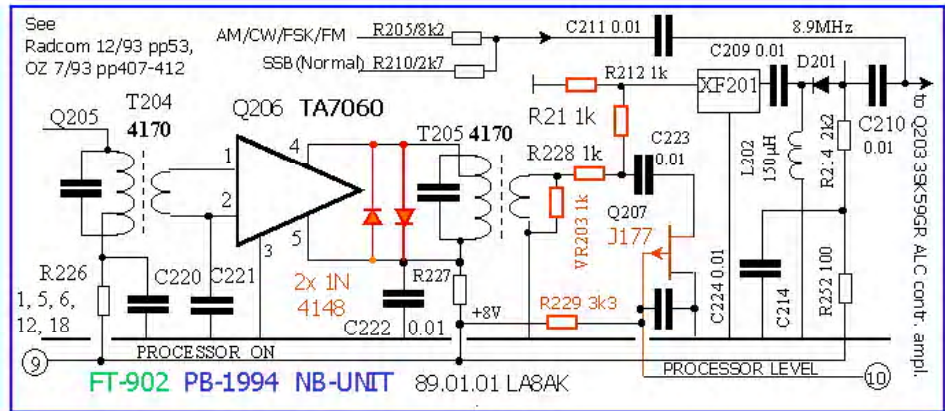

**PB-1994 NB-unit: Processor Level Control. (NB unit Q206).**

This strange circuit did not have any practical function. I used a P- channel FET, the only one available was 2N5462, while it may be possible to use the J177. Some resistors were changed too. 6-10dB variation was achieved. The rotation is now opposite way, so the center connection at the potmeter must be connected to the other side. VR203 must be at maximum, but this was later removed and a strap was inserted on the PCB to get maximum output.

The values for some resistors were later optimized and more than 10dB variation was possible for 2N5462, but for J177 almost 30dB. By the way, I believe that FT-101ZE uses similar speech processor circuit, so it may need the diodes. Later reports on the air 'are possibly the best RF processor ever heard on the bands, it is tested on 80m/40m, 6m, 2m, 70cm, 23cm, and some rather critical persons who too often criticize have said this is good and RF processor may be left on during local QSO's!

**CARRIER UNIT PB-1706A. FSK-mode.**

The dc input level is limited to +1.5V, which is an impractical level, so I have inserted a 4k7 resistor in series with base (Q701). It is now possible to use normal TTL-level input, noise treshold is improved.

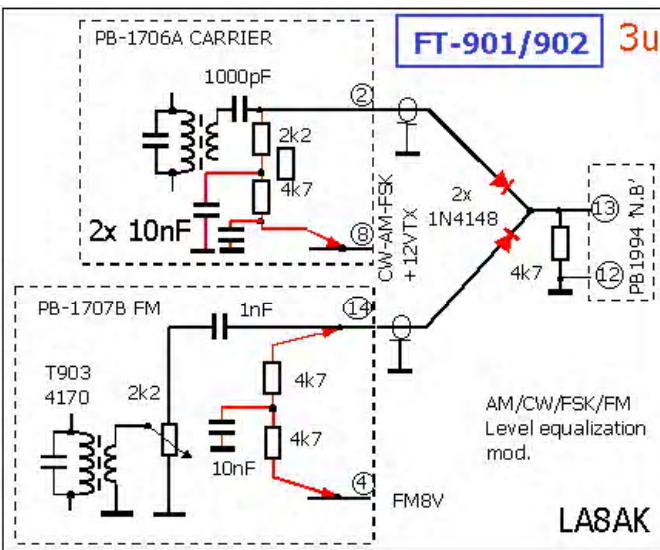

**PB-1707B FM-unit.(PB-1706A \*not cw-ms): Carrier level adjustments.**

I believe that it is important to achieve as equal level as possible for the different operations/modes, ie.(1) Normal SSB, (2) SSB with RF-processor, (3) AM, (4) CW, and (5) FM. Difficulties arise because the different units loads the common point, which is NB-unit pin 13. Diode-switching is therefore used. A diode is inserted at the FM- input to this point, see 'Overall Circuit for IF signals between the different boards'. Another diode must be inserted in the other cable from CARRIER unit, possibly on this unit, and a similar modification like the one for FM-unit must be made there. Fig. — shows the modification for FM board. In the physical location for TC901 is mounted a trimpotmeter, a capacitor goes to the output, and resistors are installed to bias the diode connected at the input to the NB-Unit. It is now easily possible to adjust the levels from FM-unit, and CW/AM signals from CARRIER unit) independently without interactions to occur. When the diode is inserted between

CARRIER unit and NB-unit the capacitor in series with cable must be removed (this has a fixed value, although it is drawn like a trimmcap). Some interesting details with the FM-unit is that it is easy to find suitable connection points for G3RUH 9600 baud modem, but it may be difficult to find some proper free pins on the connector to wire these to.











## The 6146 Family of Tubes

by

Glen E. Zook, K9STH



Probably the most used tube of all times in the final amplifier of "boat anchor" transmitters is the 6146. From the early 1950s until at least the 1980s, the 6146 found its way into virtually every manufacturer's line of transmitters. In fact, during the early 1960s RCA had a series of advertisements on the back cover of QST that listed a different manufacturer's equipment that used the 6146 each month.

There are actually three distinctive variants of the basic 6146: The 6146, 6146A, and 6146B. It is unfortunate that the 6146B was called the 6146B for it is really a different tube from the first two. Primarily the difference between the "plain" 6146 and the 6146A is the makeup of the heater ("filament"). The 6146A has what RCA calls the "dark heater". This "dark heater" is supposed to be more resilient to vibration, work well at a larger "range" of voltage, etc. Otherwise, the 6146 and the 6146A are the same tube.

In mid-1964 RCA introduced the 6146B with the "claim" of 33.33 percent higher power input than the 6146 / 6146A. Also, it was "claimed" that the 6146B could be directly substituted for the earlier tubes. The 6146 / 6146A had a maximum rated power input of 90 watts for CW and SSB operation and the 6146B had a rating of 120 watts for the same emissions.

Many amateurs are aware that the military "ruggedized" version was designated the 6146W (I will get to these tubes a bit later). However, RCA also introduced in the early 1960s the 8298 tube for use in commercial mobile equipment. The 8298 is just a "heftier" 6146A. Motorola, General Electric, and quite a number of other commercial FM equipment manufacturers used these tubes in all sorts of FM communications equipment for both low band (30-50 MHz) and high band (150.8 - 172 MHz). When the 6146B was introduced, RCA "announced" the 8298A commercial equivalent of the 6146B. In fact, most of the RCA 6146B tubes were "cross branded" with the 8298A number in addition to the 6146B.

Those companies who were manufacturing 6146 series tubes for the military changed from the "plain" 6146 to the 6146A to the 6146B as the military decreed. However, all of the tubes manufactured under military contracts were known as 6146W and, to my knowledge, nothing was done towards marking the tubes as being equivalents of the 6146, 6146A, or 6146B. The only way of telling is from the "date code" which is printed on each tube. Different manufacturers changed tube types at different times. Also, I know of no "master list" telling on what date a particular manufacturer changed from the 6146 to the 6146A to the 6146B. The only "sure" way to know if a particular 6146W is of either the 6146 or 6146A type is to look for a "code date" of before 1964 since RCA introduced the 6146B in the middle of that year. However, some manufacturers did not start manufacturing 6146B equivalent 6146W tubes for at least a year after RCA introduced the 6146B.

RCA "claimed" that the 6146B was directly interchangeable with the earlier members of the 6146 family. Unfortunately, this did not hold true in most cases. Collins, Heath, and probably other companies, at first issued various documents saying that the use of the 6146B in their equipment was "fine". But, this soon proved otherwise!

For example, when the 6146B was used in the Collins 32S-1, 32S-2, 32S-3, 32S-3A, KWM-2, and KWM-2A it was discovered that the components in the neutralization circuitry "burned up" in a very short amount of time. Thus, Collins had to retract the statement that it was "OK" to use the 6146B. Then, due to the fact that the United States military establishment wanted to "standardize" on the 6146W equivalent of the 6146B, the neutralization components had to be redesigned to allow the 6146B to be used. Fortunately, these changes did not affect the use of the earlier 6146 and 6146A in those transmitters manufactured to use the 6146B. All three types of tubes may be used without any problem in these transmitters.

Replacing the 6146 / 6146A tubes with 6146B types often results in spurious emissions, parasitic oscillations, etc. This is due to the fact that there are different bias requirements, different inter-electrode capacitances, etc. of the 6146B versus the other two. It is often difficult to neutralize 6146B tubes when used in place of the 6146 / 6146A. If neutralization can be achieved, often it lasts for just a few minutes before the tube(s) goes into oscillation.

If one insists on trying the 6146B tubes in place of the 6146 / 6146A types, the very first thing to do is to neutralize the final amplifier. If it will not neutralize, then the 6146B tubes should immediately be replaced with the older type tubes. If it does neutralize, then the neutralization should be "watched" for several hours (even days) of operation. If the neutralization changes, then the 6146B tubes again should be replaced with the 6146 / 6146A series. If the neutralization remains constant after several days, then use of the 6146B is fine in that particular transmitter.

I have, in my shack, a number of transmitters that use the 6146 / 6146A type of tubes. These include Collins 32S-1, 32S-3 (earlier model before the neutralization was changed); Heath Apache, DX-100, DX-35, SB-401, SB-110, Seneca; Johnson Pacemaker; and other transmitters as well. Every one of these is much "happier" with the 6146 / 6146A family of tubes. In addition, I have owned transmitters like the Knight T-150 and T-150A that use the 6146 tubes. Frankly, these transmitters were much happier with the 6146 / 6146A tubes.



There is another 6146 family tube that is "superior" for operation at least through 10 meters. That is the 6293. This tube was designed for "pulse" service and is rated at 1-Kilowatt pulse power input. The primary difference between these and the "normal" 6146 is that the plate is much "heavier" in its construction. Back in the late 1950s and early 1960s we would almost "kill" to get our hands on a pair of these for our DX-100s, etc. The 6293 outlasts the 6146 in "normal" service by at least 5 times and often more than 10 times the life of the tube. These tubes "show up" at hamfests, swap meets, etc., from time-to-time. If you see some of these, definitely "glomp" onto them!

The 12-volt equivalent of the 6146 is the 6883, the equivalent of the 6146A is the 6883A, and the 6146B is the 6883B. Now, there are the tubes that were manufactured for FM commercial service. These series go as follows: 6883, 6883A / 8032, 6883B / 8032A / 8552. Again most of these are "cross branded" with all of the tube numbers that are equivalent.

From 1970 until late 1979 when Motorola went out of the reconditioned equipment business, I owned the Motorola reconditioned equipment center for the south-central United States. We reconditioned Motorola FM equipment for 14 states, everything that Motorola sold reconditioned that was exported, and everything that was sold to the United States Government (this was the height of Viet Nam and the Government did buy reconditioned equipment!).

At that time, the Motrac series of mobile equipment was very popular. Depending on the model, these normally used one, or two, of the 6883A / 8032 tubes. It was only in the very "latest" models (HHT "E" series, LHT series, and MHT series) that Motorola had redesigned the equipment to use the 6883B / 8032A / 8552 tubes. Around late 1976 or early 1977, Motorola decided to eliminate some of the tube types that they were "stocking" at the Schamburg, Illinois, parts depot. Thus, they started shipping 8552 tubes in boxes that were marked as 8032. The Motrac is unique in the fact that you cannot see the tubes when they are in operation (they are enclosed in a metal "heat sink"). In fact, it is difficult to even "tune" a Motrac when the heat sink is not in place.

We went through from 50 to over 100 of the 8032 type tubes per week and within days were "down" to using the 8552 tubes in the 8032 boxes. Within a very few days of starting to use the 8552 tubes we started receiving complaints that virtually every Motrac unit that was received by customers arrived with one, or both, tubes broken. Prior to this we had never had a single complaint. Upon investigation we found that the 8552 tubes had so many parasitic oscillations that they were getting so hot that the glass envelope was being annealed! This was happening within a minute, or two, of tune-up and final quality control. When the radio was subjected to normal vibrations of shipping, the glass envelope of the tubes was being shattered.

This was reported to Motorola. At first they refused to believe us saying that we must have gotten a "bad" shipment of tubes. But, within a couple of weeks they received over 1000 complaints from their service stations about exactly the same problem. It cost Motorola one "heck of a lot" of money to pay the warranty claims because they had tried to "cut costs" by eliminating the earlier type of tube. They had to re-box all of the 8552 tubes that had been put into 8032 boxes and get in a "rush" shipment of 8032 tubes.

The whole problem stemmed from the fact that the "B" series of tubes is not the same as the "plain" and "A" series. The parasitic oscillations were caused by the different bias requirements and by the "fixed" neutralization of the driver and/or amplifier tube in the Motrac. There was no practical way to change the circuitry to handle the "B" series tubes. Also, making such a change would void the "type acceptance" of the units.

In a "practical" sense, it is "OK" to mix 6146 and 6146A tubes since the primary difference is in the design of the heaters. But, NEVER mix 6146 / 6146A tubes with a 6146B! This is really "asking for trouble".

Also, in a number of transmitters and transceivers (especially the Heath SB-Line) the heaters ("filaments") of the pair of 6146 tubes are in series. In these units it is very easy to change the heaters from series to parallel and substitute the 6883 / 6883A / 8032 tubes. The 12-volt equivalent tubes are often available for "pennies" because of the vast number that were used in the commercial FM market. I have done this with my Heath SB-110A and it works "like a champ". If you every want to change back, it is a very simple operation to do so.

I know that there are amateurs who say that they have used the 6146B tubes in place of the 6146 / 6146A without any problems. I can definitely believe that. But, I have seen way too many examples of the 6146B causing problems in relation to the cases in which the substitution has no effect. As I said before, neutralize and keep checking the neutralization for several days if you do replace your 6146 / 6146A tubes with 6146B types. Otherwise, you can find yourself with TVI, "burned out tubes", and other damage to your transmitter.

You must be VERY careful when dealing with the various tubes of the 6146 family, otherwise you just might be in for some very interesting problems. Substitute if you must, but, be aware that you are "treading on thin ice".

Copyright article: Glen E. Zook K9STH, reprinted with his permission, tnx Glen!  
More interesting articles on his website: <http://home.comcast.net/~k9sth/>





**N5HNY** Rating: 5/5 Apr 10, 2004 00:48  
One of the all time greats Time owned: more than 12 months

I shared a house with a friend of mine in the 80's. He was an extra and encouraged me to get back into Amateur Radio. I was a Novice in the early 70's. One of the many rigs he had in the shack was a FT-901 DM. It was awesome. I was used to old boat anchors and surplus military gear. I bought one off E-bay about three years ago and I haven't regretted it. I agree that the noise blanker is wanting. I also have a problem tuning up on 40 meters. My friend had the same problem with his. I paid about \$375 for mine. The only thing better would be the FT-902 that has the WARC bands. You can't go wrong with this radio.

**W4ACW** Rating: 5/5 May 13, 2002 11:51  
Love this radio.... Time owned: more than 12 months

I got this radio 2 years ago and it was never used! Wrapped in a plastic bag and sat on a shelf. The owner never used it and passed away. I bought it from the widow. When it arrived the frequency readout was all out of sorts reading wrong ... Looked in the maintenance manual and saw that certain serial#'s had a reversed electrolytic capacitor. I opened the radio and replaced the capacitor. The insides and outside are new. I guess the owner didn't bother using it put it on the shelf with the factory defect. The radio works beautiful. It has a total of 20hrs. on it! I keep it covered and use it now and then as my back up radio. I wish I knew the WARC mod. I didn't know abt that one! A classic and a keeper! Not for sale...sri

**W3HKK** Rating: 5/5 May 13, 2002 09:29  
A classic sturdy reliable rig that holds up well. Time owned: more than 12 months

Bought mine in 1979 for heavy dxing and contesting, and earned several top scores in my ARRL district with it. Lets you dig out the hard to get ones in intense QRM. Great audio on rx and tx, with built in processor. Mates very well with the Shure 444D mic for glowing audio reports

For its time, the 901 had all the bells and whistles expected of a state of the art xcvr. And it still looks great! Its controls are smooth, mechanically and electrically its extremely reliable, and a joy to operate, on ssb or cw (with built in keyer, a sharp audio peak filter AND variable bandwidth tuning- an excellent combination for cw and data.)

Stability, even after 23 years of heavy use, is decent...mine drifts about 400 khz from a cold start over a 2 hour period, then stabilizes. Finals last many years and the rig just keeps on ticking. In 23 years I have replaced two blown diodes in the power supply, and the tubes a couple of times( 6146B or 6146W's- not expensive...+ the 12BY7A preamp) Neutralization and alignment can easily be done at home. FM, RTTY, AM are also built in for a little variety.

**NEGATIVES:** Rig is pre-WARC (but can be modified); the notch filter doesn't notch deep enough to take out carriers ( I use an outboard audio DSP for this)..only about 30 db; you must manually change from LSB to USB; the noise blanker is minimally effective( again I use an outboard DSP); and as with all tube rigs it is a manual tune rig.

**MISC:** You can find a great selection of top notch outboard accessories for it. My complete station includes: external vfo, external speaker, multiscope, vhf/uhf xvrtr, antenna tuner and dummy load. All work flawlessly.

The best investment I ever made.

de Bob W3HKK

**VE6BUD** Rating: 5/5 Feb 22, 2002 11:47  
Great Rig! Time owned: more than 12 months

I purchased a rather beat up FT-901DM from a ham back in 1993 for \$750 CDN. I still see them selling for around \$500 today. The FT-901D(M) is one of the very few rigs from this particular vintage that has an AGC fast enough to handle AMTOR. It does it very well. The TR relay is fast enough to handle it. I've found that with some rigs, you can't even turn off the AGC or that "Fast AGC" isn't fast enough for AMTOR or high speed CW. Being able to shut off AGC on this rig is a great asset.

The Audio Notch feature (APF) is a very useful feature. I used it to work very noisy CW but I can see it being priceless for use with PSK31. The IF Shift and Notch filters are a Godsend for working RTTY and other digital modes.

Most rigs from this era don't have this feature. (It's almost like Yaesu crippled down the FT-901DM to make the FT-101ZD!)

The geared down Plate and Load controls are very precise and very easy to use with the Tune button.

My only beef about this rig is the preselect control. I realize that all rigs from this vintage usually had some variation on this control, but it reminds me a bit of the carrier balance control that my old Eico 753 had. Yes, it's obsolete and a bit dated but the other features this rig has make up for this little setback.

If you want a cheap rig for use with the digital modes of yesteryear and today, this is the perfect radio to use for them, without having to go DSP or investing more than \$500 on a newer solid state rig.



**KB0TIC** Rating: 4/5 Oct 2, 2001 01:02  
I Just Bought It Time owned: 0 to 3 months

Hi , I just got this 901 DM and I love it. At the present time, I am a Tech, but owning this radio, you want to upgrade. Right now, it does not transmit, but it is more fun to just listen. The smartest \$150 I have ever spent.

**WA3PHT** Rating: 4/5 May 22, 2000 19:52  
Takes a while to load but works great. Time owned: more than 12 months

Ive owned a 901 for about 14 yrs. Worked 10m-160. I also enjoy 10m FM.CW is a little weak but the audio reports even on QRP are excellent.Probably the best Rig I have owned.

**KB1ELV** Rating: 5/5 May 22, 2000 15:40  
Awesome rig!! Time owned: 0 to 3 months

I have had the rig for a few weeks now and it works great. I can run 200w no sweat!! The audio reports are great, but remember to back off on FM. There are mods out there to do 30mtrs, and make the reciever recieve 5mhz-6. I would have liked a nice general coverage reciever, but thats ok. Anyway, a great rig for the 200 I paid for it, go and get one at the next flea!!

73,  
KB1ELV@Hotmail.com  
Chris

**LU3FCK** Rating: 4/5 Mar 11, 2000 16:05  
Nice Radio Time owned: unknown months

Its a nice rig, good receiver not as newer rigs but good the only thing i miss is that i have the D version without memory so cant work split. its a nice radio for people getting on radio its cheap and is good

**W0LMN** Rating: 4/5 Feb 12, 2000 16:56  
One of the original great Transceivers Time owned: unknown months

This is a fine transceiver! I bought mine about 16 to 17 years ago - when they first come out. It has performed faulesly ever since. The sensitivety may not be what the newer modern day rigs are capable of but it is very serviceable. The only repair made is one recent one, one of the panel lights in the meter burned out - Yaesu still has replacement parts. The tube finals and driver tube are still going strong, having never been replaced. If I were to guess how many hours of operation and contacts were made, hours approximately 6,000 and contacts about 10,000. Hard to beat the FT-901DM for base station or mobile use.

**MW0HRD** Rating: 5/5 Jan 5, 2005 18:45  
good solid radio Time owned: more than 12 months

I have now owned my FT902DM for about 16 months and for its age had only the usual problems when i first got the radio relays switches etc nothing much. I have worked the world on it and would not part with it never had a bad report the audio is superb. with 100w out I paid £150 you cannot go wrong. I would recomend this radio to anyone. but do not get one if you dont like to plate & load 73 to you all Chris S-Wales

**PY3KT** Rating: 5/5 Dec 20, 2004 08:44  
Great radio Time owned: more than 12 months

I appreciate so much this type of equipment, therefore as a friend said: "tube radios have soul". Excellent receiver and trustworthy transmitter, with good quality of audio. It is between my preferring, because remembers my old Yaesu FT101-ZD and it adds quality in all the directions.

73 and greetings from Brazil  
PY3KT - Joel Costa

**VE8NSD** Rating: 5/5 Oct 15, 2004 11:27  
I like mine, but... Time owned: more than 12 months

I got mine as part of a package deal with the phone patch, ant tuner, VFO, and `scope. The Astatic D104 really makes the audio sound good. I received a lot of unsolicited compliments on my TX audio.

I saw an Inrad SSB filter on eBay, bought it, and love it. The transformation is literally like having a different (better) receiver. Really incredible. BUT the drawback is that the receive audio now is "communications" quality instead of "high fidelity".

**G1EUZ** Rating: 5/5 Aug 12, 2004 12:08  
Keeper Time owned: more than 12 months

I have 2 Radios, the ICOM 718 and the FT-902DM.  
It took me 12 Months to refurbish the 902DM fully, I bought it with several parts missing, and managed to track them down via the



web. Now I cannot leave it alone.

A useful link for the counter board replacement chip is here:

[http://homepage3.nifty.com/RadioGaGa/COUNTER\\_e/](http://homepage3.nifty.com/RadioGaGa/COUNTER_e/)

also check out the 901/902dm group on yahoo:

<http://groups.yahoo.com/group/FT-901/>

The modern Icom rig is great for fast fun, but for that lamplight and heater glow, I keep returning to the 902DM. Alignment can be tricky, but when you get it right - it's great.

Mick

**G3ZPS** Rating: 4/5 May 31, 2002 18:17  
Great value for money Time owned: months

After a 20 year break from the hobby I started collecting Yaesu FT rigs of this vintage in 2002. Maybe its my age but for me they are easier to repair.

I couldn't turn down my FT902DM, with phone patch speaker and FC902..almost unmarked!! Output pwr was low on all bands (less than 70Watts) compared to my 101ZD's and this was quickly traced to a defective OP tube, now well over 100W on the lower bands. The Receiver is excellent with a very low noise floor. One of the main differences to the 901 is the diode first mixer (instead of FETs), also many of the Yaesu 901 mods are fitted. The 10 second tune up timer can be annoying for old hands who can tune up tube rigs without it. Memory is basic, but useful for checking back on stations on the band you are on.

The 902DM has AM and FM options fitted, the narrow CW filter was I think an option, but with the Audio Peak Filter its a pretty good CW rig. I'm certain there is no 902DM workshop manual just the 901 manual with an addendum for the 902.

Also very heavy compared to tiny modern rigs. As they say.. its a keeper!!

G3ZPS London UK

**W3HKK** Rating: 5/5 May 13, 2002 09:54  
A classic all-mode rig for great ssb and cw Time owned: more than 12 months

I have used an FT-901DM (see my other review) for 23 years and love it. In fact, I still use it as a back up station on a regular basis. So, two years ago, when I came across a complete, like-new 902 station, for sale at a ham fest, I couldnt resist. I agree with all the other 902 commentaries. Its a quality durable professional grade xcvr with great flexibility and multimode operation. It excels on ssb and cw.

I too stumbled a bit when trying to align it due to errors and omissions in the owners manual. (what Yaesu did was a poor job of updating the FT-901DM manual to cover WARC band alignment procedures.) But after one stumble, and a day or two to regroup, I added the missing steps, and completed the neutralization/alignment- with terrific results.

MY 902 had been modified for cb use, so watch out for this. But it is a simple matter of ordering replacement xtals ( 4) and tweaking BOTH the XTAL Unit and the VCO unit to restore normal output on 10M.

This remains an exceptional rig and has held up amazingly well for its age.

de Bob W3HKK

**WU6Q** Rating: 4/5 Oct 2, 2001 12:53  
A Solid Performer !! Time owned: more than 12 months

The 902DM is a good solid radio, built to last. Having the WARC bands, offering split operation and AM/FM, make it a very versatile radio. It's through whole technology, pretty easy to work on, however, alignment is critical. The manual I have which identifies the respective coils and caps to adjust for the transmitter and receiver is in error. Once I figured it out, the radio is working great. One strong feature is the built in 120VAC supply, no external power supply needed. I have another plug to operate from a battery 12VDC supply if needed. Also remember the USB and LSB are 3 kHz apart, so when you flip over to the other side-band you'll need to retune 3 kHz unlike the newer equipment. The "tune" button is a much better idea than the Kenwood tune mode of having to rotate a knob through all the different modes, with the 902 you can just push the button to tune and it kicks off by itself thus helping save your finals. It's a lot of radio and ergonomically laid out well. 73.....tom

**JK** Rating: 5/5 Jul 10, 2001 15:10  
This is a good receiver (and hopefully a good transmitter) Time owned: 0 to 3 months

Hi, i never knew until today when i saw this webpage, how brilliant this transceiver really is.

i saw mine for sale at a radio rally for £145 and i did have second thoughts about buying it (which i should not of had),but the price was right so i bought it. I have tried it out on receive and seems a good receiver, i am still waiting ( un-patiently) to try it out on transmit mode, but i need a good antenna so i hope the transceiver is brilliant at transmitting and wont let me down....

its solidly built and has a good range of frequencies but as someone pointed out before it does not cover the full band of frequencies(0-30 Mhz) so this is a bit disapointing. but im planning to buy another transceiver to do this for me.

its dual display makes it easier to tune compared to older setups which just have a analogue display, Its got a good selection of modes for each band (god knows what FSK stands for!).





i never knew that it had a built in keyer so this makes my expectations of it a little higher than before.  
im hoping to get a good selection of QSL's from all over the world.

73's for now, JK

P.S if anyone has any Antenna suggestions for me please email me at JK@netking.20m.com

**N5JNX** Rating: 5/5 Oct 31, 2000 15:27  
Excellent Transceiver Time owned: more than 12 months

Howdy to ALL,

This is just my opinion. As you know, we all view an empty glass differently. I will start with the cons first and then the pros. I know, most would like to hear the pros first.

The CONS:

Try finding the extender boards (hee hee). Although not necessary, they make it a breeze for aligning, repairing, and troubleshooting. Misprints in the operations manual. Be very careful, because you could really mess things up. The operations manual does not appear to provide any instructions on how to align the WARC bands. Eventually, I will develop a procedure and post it on one of the newsgroups. There was never a service manual that I know of that was created for the FT-902DM.

Hybrid transceiver-meaning you are required to peak the preselector, dip the plate, and then increase the loading. This will result in the transmitter/receiver section being resonant and providing maximum power on transmit and receive, provided your stages are aligned correctly. One way to peak the preselector is to use the marker on the front panel of the transceiver.

No general coverage receiver. Perhaps the deciding factor between a true SWLer and a Ham?

The PROS: If you can find one, this is the one to buy. I recently sold my TS-940S/AT for the FT-902DM. I prefer the FT-902DM. I like the quality of the audio (some say the receive audio appears basey).

When working CW, the audio peak filter is excellent. For me, I don't need an additional filter; however, some folks like FoxTango Filters and Yaesu may disagree.

The width/reject controls are pretty neat for getting rid of adjacent frequency interference. I would like to eventually try a filter for this to see what sort of difference it makes. So I may be knocking on FoxTango's or Yaesu's door pretty soon.

Single channel VFO, try getting this feature on a TS520, TS530, TS820, or TS830. I don't think you will find it built in as with the FT-902/901 DM series radio. No fixed crystals required. You will be able to operate 10 meter FM repeaters and split operation on all bands; however, it does not appear to work crossband.

Built in CW keyer. Need I say more for those that believe in the power of dits and dots.

AM is clean on transmit as well as receive. Don't have the power to compete with the big guns on 10 or 80. But when the opportunity presented itself on 10, guys thought I was running some old Globe King job.

Well, that ends my review of the FT-902 DM. Now for the fun stuff-The Accessories.

Using the transverter (FTV-901R) is a pleasure. The only thing I have to do now is go into the FT-902DM and connect my tone board. Once this is done, I will sell my little all mode 2 meter radio.

The only thing left for me to do, is locate a FV-901DM- The VFO. These things are pretty neat, because they allow you to store 40 channels. This is ideal for use with the transverter.

Count the number of times you have seen 520s, 530s, and 830s for sale. Then count the number of times you have seen FT-902s for sale. I think there is a reason for it.

If you are looking for a hybrid to give you that old Ham feel, then get a FT-902DM. You will not be disappointed.

73 and take care.

N5JNX-(RFII)

**KC2GBS** Rating: 5/5 Oct 24, 2000 09:20  
Fantastic Radio Time owned: 0 to 3 months

I have had this radio for a relatively short time. My first impression is that its VERY well made. I am able to pull in some distant stations even with a not-so-hot antenna setup. I am a big Yaesu fan and that is one of the reasons I decided to go with this one. I also picked up some of the accessories for it (hard to find,)including the transverter and antenna tuner. Overall I am very satisfied with it. I would recommend it to anyone interested in a high quality older radio

**KJ1R** Rating: 5/5 Jul 9, 2000 22:50  
A GREAT WORKHORSE!! Time owned: 3 to 6 months

What an impressive radio to operate. I have owned three 902dm's in my ham years, and all three of them performed like a charm. Very easy to operate, and includes all the bells and whistles you need to get on the air. Excellent design, and easy to work on (if needed). I was fortunate enough to find one in pristine condition, along with FC-902 tuner. If you find one out there for sale, don't think twice - it's a keeper!





# Counter Replacement Module

Text and explanations by Teruhiko Hayashi ( JA2SVZ ) [http://homepage3.nifty.com/RadioGaGa/COUNTER\\_e/](http://homepage3.nifty.com/RadioGaGa/COUNTER_e/)

For YAESU FT-101Z / FT-107 / Sommerkamp FT-307 / FT-707 / FT-901,902 (later version)

## DISPLAY COUNTER UNIT (PB-2086A)

### Custom Integrated Circuit (MSM9520RS) Replacement Module

Is your precious, beloved 101ZD still displaying the frequency?

"Pre-DSP/MPU era transceivers" from YAESU often made use of a custom integrated circuit (IC), MSM9520RS in their DISPLAY COUNTER UNIT. The bad news is that MSM9520RS is somewhat prone to failures. Since this particular IC was not a standard product but a custom ordered IC by YAESU and its production has been discontinued for long time, there is very little hope to obtain a replacement part for repair, even at world famous TOKYO AKIHABARA!

This replacement module takes advantages of the flexibilities of PIC microcontroller (PIC 16F873) to "simulate" the exact functionalities of MSM9520RS in the DISPLAY COUNTER UNIT: PB-2086A, equipped in FT-101Z, FT-107, FT-707 and FT-901/902. This module restores their frequency display functionality when MSM9520RS fails.

Those YAESU models were designed and produced at the "supreme" of analogue technologies and can still perform "beautifully" when properly maintained. (and with frequency display, of course!)

My FT-101Z came from one of my friends several years ago and like many others, the frequency display was nonfunctional: MSM9520RS was dead. Since the entire transceiver except its frequency display was functional and in good shape, I decided to develop this PIC replacement module for myself. It did not take too long for me to realize that many people in the world are desperately looking for MSM9520RS and I started thinking I can be of their help.

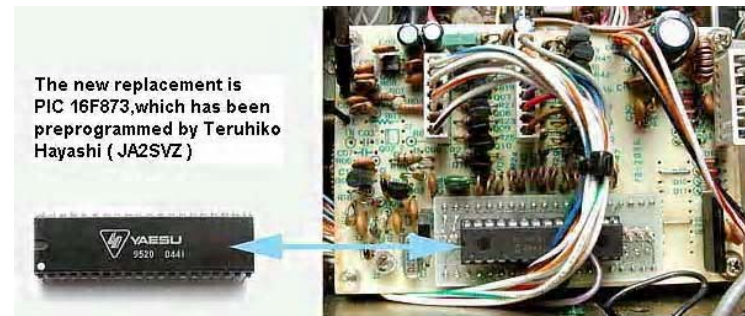
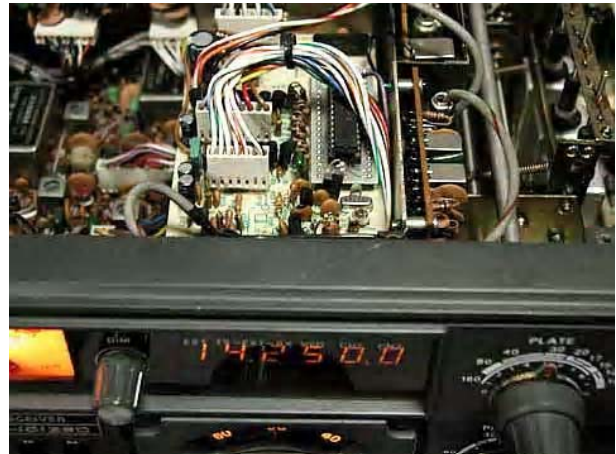

The new replacement is PIC 16F873, which has been preprogrammed by Teruhiko Hayashi (JA2SVZ)

### Applicable Models

Originally this module was designed for and tested in my YAESU FT-101Z but thanks to other enthusiastic volunteers, the applicability of this module to other YAESU models has been verified and tested. So far, the following YAESU models can make use of this replacement module.

FT-101Z FT-107 FT-707  
FT-901/902 (later version only)

For FT-901/902, the early versions did not use MSM9520RS for its frequency display; therefore the early version is not applicable. The later version can be distinguished with its brightness control knob: "DIM" located on the left side of the frequency display. Also, the DISPLAY COUNTER UNIT is marked as PB-2086A, with MSM9520RS 40 pin DIP IC.

### Contents of the KIT

This module is offered as a parts kit form. It contains a custom made, double sided printed circuit board for converting the 28 pin of the PIC microcontroller to 40 pins of MSM9520RS, programmed PIC 16F873, 20.000 MHz crystal (for frequency measurement standard as well as PIC clock generation) and resistors, capacitors and a transistor for modifying the preamplifier circuit on the DISPLAY COUNTER UNIT: PB-2086A.

The Assembly and Installation Manual is available for download.

Please contact Teruhiko Hayashi (JA2SVZ) by e-mail: [thayashi@ta2.so-net.ne.jp](mailto:thayashi@ta2.so-net.ne.jp) for ordering information, S/H cost estimation and for other technical information!

**Prerequisite:** It is necessary to unsolder 40 pin DIP IC (MSM9520RS) from the board: this may be a little challenging if you are not familiar to. You need to deal with fine foil patterns on the conversion printed circuit board: routing between 1/10 of inch DIP IC pins. Usually it takes a couple of hours for someone who often conducts transistor/ IC projects as a hobbyist to complete the assembly, installation and adjustments.

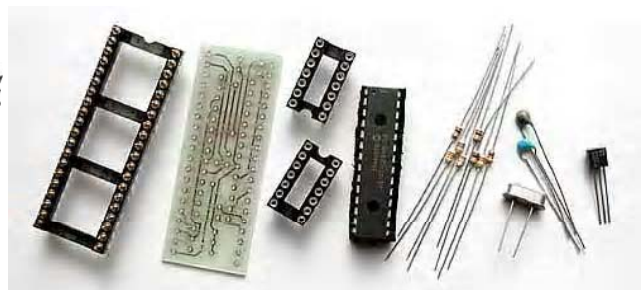



## VFO stability story by Dan WB5TKA

We all know about the Roaming Gnome. He's the little guy who is never still, but rather travels the world sending back post cards from the numerous exotic places he visits, when in fact he should be sitting still. Rock still, in the garden. The gnome's travels may be humorous but when your radio frequency travels, all humor goes out the window. The dial is supposed to stay put, just as the little concrete guy is suppose to stay put.

A couple of years ago I obtained a very nice and very clean Yaesu FT-902DM. Now this is one fantastic radio. Not only does it, unlike so many other transceivers, have the power supply built right inside the case, it covers all of the WARC bands - all bands from 160 through 10 meters - and operates all modes including AM and FM. Great for 10 meter operation. I won't outline all of the features. Simply take it that it's a very nice radio. It's from an earlier era so it does contain valves (ok, tubes for us on this side of the pond) in the transmitter (driver and PA) so more "tuning" is required than for current solid state rigs. Yes, the receiver is all solid state. It's been a fun radio to operate and makes a great rag chew rig for such bands as 17 meters.



Alas, all is not perfect with this radio. It suffers from a bad case of frequency drift. It requires a very long warm up time to stabilize enough to hold comfortable QSOs. Naturally following a station that drifts away from you while you're trying to carry on a chat is annoying.

The drift is downward in frequency and amounts to several KHz over a period of time, and is consistent on all bands. I determined to resolve the problem by finding the source of the malfunction and correcting it. I said that because some of the advice I received when I inquired on a couple of Yaesu email lists was to take the easy way out and simply get and use the external VFO which mates with the rig. Now having that VFO is certainly ideal and someday I'd like to get one but not for the reason given. The external VFO would allow split frequency operation further adding to the rig's utility.

I monitored the output of the internal VFO and noted that it increases in frequency. By the way, I must add that the drift is heat related. With the filaments turned on and especially while transmitting, the heat buildup is greater and thus the drift is accelerated. That told me on thing. The VFO is using temperature compensating capacitors and the compensation is too much. Surely, it did not leave the factory in that condition, so one must presume that the values selected for the circuit are correctly arrived at. Probably, component values have changed with age. Something has gone bad.

The original complement of capacitors within the tuning portion of the VFO, besides the variable ones, consisted of (in parallel) a 33 pf NPO, a 15 pf NPO, a 3 pf N750, and a 12 pf N750. A total of 15 pf N750 temperature compensation exist.

I ran a couple of tests. I removed both of the temperature compensating caps. but to insure that the total capacitance remained the same, I temporarily tacked in a 15 pf NPO. As expected, the VFO drifted down in frequency. Remember, the VFO had drifted higher in frequency originally. I then added only the 3 pf N750. The VFO still drifted up, but of course not as much as with no temperature compensation. I needed more.

I replaced the 3 pf with the 12 pf N750 and now the drift is downward again. Not nearly so much as at first. Now the drift is much slower (less distance over time) and ends up no more than about 1.5 kHz over a 12 hour or more time period. Not bad, but still not good enough. Far from it.

By rights, something less than 12 pf and more than 3 pf of temperature compensation is needed. Either a capacitance value of perhaps even one of like capacitance but a lower compensation. A N220 perhaps.

I don't know what the final solution will be yet. My next steps will involve some experimentation with different values of temperature compensation caps. At the same time, I will be looking further into the existing components seeking a clue about the real cause of the problem. The caps. I've checked so far have measured very close to their stamped values. That does not mean (if it's possible for this to happen) that one of the temperature compensation capacitors has changed its characteristics. I'll update this article as work progresses.

August 13, 2004. I'm a week or two behind in adding this update. The good news is that the radio is back to normal operation. I removed the recently installed 12 pf N750 and put the 3 pf N750 back in. As before, the drift reversed direction. Drifting up in frequency. I installed - mainly because it was the closest I had for something less than the previously installed 12 pf, an 8.2 pf N220. I'm not sure I could have come much closer had I a large assortment of sizes to work from. Drift now for all practical purposes is gone. After about an hour of warm up time, it's up in frequency only 300 Hz. The manual lists the stability as less than 300 Hz after 10 minutes of warm up and less than 100 Hz after 30 minutes warmup.

I set the dial to read 14.275.0 (no particular reason for picking that frequency) and after 24 hours, the frequency was rock solid at 14.274.8. The warm up time included having the filament switch on to help insure that the heat build up within the radio would be similar at least to normal use. The 200 Hz change, I can live with. It's certainly a vast improvement over the original drift which would have been perhaps a couple of kHz or more.

Now with the radio back in good working condition there is one more thing I am going to have to attend to. The two PA tubes appear to be soft. In the tune mode, the power after tuneup reaches perhaps 90 watts but falls off within a few seconds to perhaps 60 to 70 watts. So an investment in a new matched pair of 6146 tubes is in order.

Questions? Comments? Contact me.  
wb5tka

Article courtesy of Dan WB5TKA

More on his website: <http://www.dooleystreasurechest.com/wb5tka/index.html>





## 8989khz Interference Trap filters and trimmer positions:

Strong IF signals can reach the IF amplifier and causes a annoying background noise, that is always there, independent from the tuned signal. In my case, there is a strong RTTY station operating at 8989khz, about 100km from my shack. There is a trap filter to attenuate this signal (even two in the early version with the Fet mixer), but they are not documented in the manuals.

The traps are on trimmer boards PB-1723C (T02 and TC07) and on PB-1724C (only in early FT-901DM),(T02 and TC07). The early types alignment is done by tuning the trimmers, in the later versions, alignment is done by tuning the core. See the pictures below for the exact alignment positions.

Alignment of the 8989khz trap: Go to 20m

Apply a suitable signal of 8989khz to the antenna plug.

Tune the preselector for maximum (around S9+20db) signal. (preselector around 2 on the log scale)

Tune the traps now for minimum signal, increase the input signal if necessary to obtain a real minimum.

That's all. In normal cases the unwanted IF signals are now practically gone, in my case it is very much reduced, but still there. When working real weak DX stations, it is still a problem.

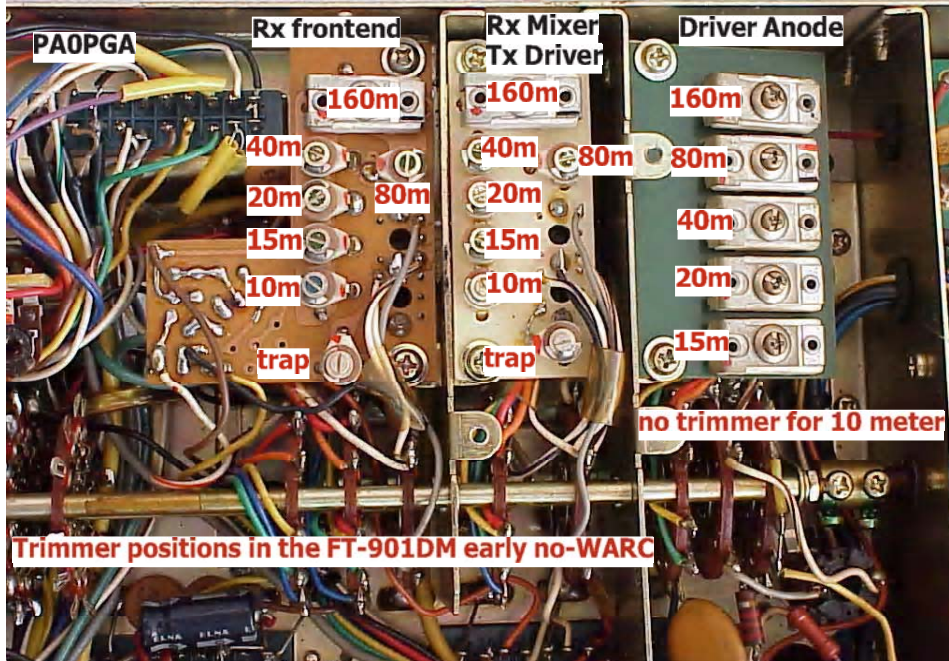

Trimmer positions on the early FT901DM (left),

Trimmer positions on the later FT901DM and FT-902DM (below) (courtesy of G3UGY)

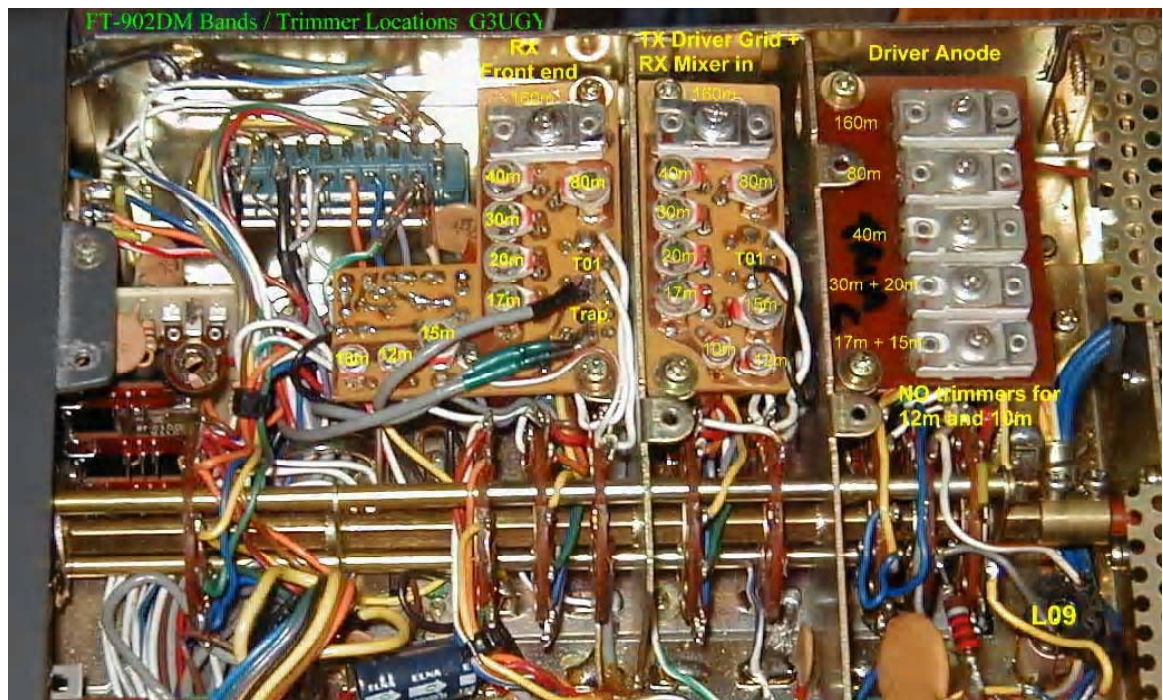



### FT-901 Remote connector

This remote connector can be used to switch together with the band in use, a external device, it delivers 12 Volt dc for powering a relay (antenna switch, tuner,).

Pin:	901 noWARC,	901/902 WARC
1	160m	160m
2	80m	80m
3	40m	40m
4	20m	30+20m
5	15m	17+15m
6	10m	12+10m
7	ground	ground



Yaesu used not the standard DIN numbering, so you have to check your voltages to be sure. I measured the connections shown above. The bandswitch supplies 12Vdc on the remote connector at the positions shown. This output can be used for switching antenna's, antennatuners or other band related equipment Use a low-current relay ca 100mA.

### dB conversion table as used by Yaesu for alignment of their equipment.

$$0 \text{ dBu} = 0.5\mu\text{V}/50 \text{ ohm}$$

Yaesu used in manuals HP 606A signal generator

dBu	Volts	dBm
-6	0.25uV	-119
0	0.5uV	-113
6	1uV	-107
12	2uV	-101
24	8uV	-88.9
30	15.8uV	-83
40	50uV	-73
50	158uV	-63
60	500uV	-53
70	1.58mV	-43
80	5mV	-33
90	15.8mV	-23
100	50mV	-13
	224mV	0
120	500mV	7

(dB table courtesy of Jerry Becker)

### C-1701 Problem in the FT-901/902



Harry Leeming, G3LLL, our FT specialist, advises to change always the coupling condenser between the driver anode and the PA grids, because it is one of the common sources for PA troubles. This condenser develop a leak or goes bad altogether, with excessive PA currents as result, destroying the PA tubes. Replace with a good 100pf/3KV type condenser. This condenser is located on the PB-1715A PA board. Remove the tubes and the board, the C can then easily be removed. You can solder the new C on the solder side for quick access, there is room enough.

Have you something that is of interest for the big group of FT-901/902 users, please drop me a line for insertion in the next issue of this Survival Guide.

